

804527

BEST AVAILABLE COPY



Best Available Copy

Pratt & Whitney Aircraft
FLORIDA RESEARCH AND DEVELOPMENT CENTER

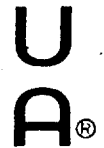

720

SPECIFICATION NO. 2710

(11) 8 AUGUST 1966
(12) 69p.

JTF17A-21B TURBOFAN
ENGINE SPECIFICATION

(14) Spec-2710

(15) FA-SS-66-8



Best Available Copy

~~(COMPETITIVE DATA)~~

DDC
RECORDED
JAN 9 - 1967
APR

Pratt & Whitney Aircraft
FLORIDA RESEARCH AND DEVELOPMENT CENTER

DIVISION OF UNITED AIRCRAFT CORPORATION

U
A®

mt

DC

No 208 A
(401 355)

2c

BEST

AVAILABLE

COPY

TABLE OF CONTENTS

1.0	SCOPE
1.1	Scope
1.2	Specification Performance and Installation Drawing
2.0	APPLICABLE DOCUMENTS
2.1	Government
2.2	Non-Government
3.0	TYPE AND DESCRIPTION
3.1	Installation
3.1.1	Dimension and Installation Drawing
3.2	Dry Weight of Engine
3.2.1	Weight of Residual Fluids
3.3	Engine Mounting
3.4	Requirements
3.4.1	Materials and Processes
3.4.2	Standards
3.4.2.1	Parts
3.4.2.2	Design Standards
3.4.3	Parts List
3.4.4	Interchangeability
3.4.5	Accessibility
3.4.6	Maintainability, Reliability, and Safety
3.4.7	Engine Expansion Dimensions
3.4.8	Flight Maneuver Forces
3.4.9	Ground Handling
3.4.10	Engine Inlet Flange Design Load
3.4.11	Containment and Rotor Structural Integrity
3.4.12	Flammable Fluid Systems
3.4.13	Engine Connections
3.4.14	Connection Identification
3.4.15	Engine Mounted Airframe Accessories
3.4.15.1	Use of Integral Oil Systems for Accessories
3.4.15.2	Engine-Supplied Support Brackets for Airframe Accessories
3.4.15.3	Cover Plates
3.4.16	Useful Life
3.4.17	Identification of Product
4.0	MASS MOMENT OF INERTIA OF ROTATING PARTS
5.0	VIBRATION
5.1	Airframe Vibration Testing with Installed Engines
6.0	ENGINE PERFORMANCE
6.1	Performance Ratings
6.1.1	Guaranteed Standard Day Calibration Stand Performance at Sea Level
6.1.2	Guaranteed Steady-State Performance Ratings at Standard Altitude Conditions
6.2	Estimated Engine Performance
6.3	Flight Conditions
6.4	Atmospheric Liquid Water

TABLE OF CONTENTS (Continued)

6.5	Ambient Temperature Conditions
7.0	ENGINE OPERATING ENVELOPE
8.0	THRUST TRANSIENTS
8.1	Stability
8.2	Response
9.0	PRESSURE AND TEMPERATURE CHANGE
9.1	Inlet Pressure Transients
9.1.1	Minimum Exhaust Pressure
9.2	Inlet Temperature Rate of Change
9.2.1	Normal
9.2.2	Emergency
10.0	INLET AIR PRESSURE DISTORTION
11.0	INLET ANTI-ICING
12.0	FOREIGN OBJECT INGESTION
13.0	EXHAUST SYSTEM
13.1	Secondary Airflow
14.0	LUBRICATION SYSTEM
14.1	Oil Type
14.2	Oil Consumption
14.3	Oil Pressure and Temperature Limits
14.4	Oil Quantity
14.5	Oil Tank
14.6	Oil Flow Interruption
14.7	Drive Pad Lubrication
15.0	FUEL
15.1	Fuel Temperature Limits
15.2	Fuel Pressure Limits
15.2.1	Fuel System Design Pressure
15.3	Fuel Recirculation
15.4	Fuel Cleanliness
15.4.1	Fuel Contamination
15.4.2	Fuel Filters
15.5	Fuel Leakage
15.6	Combustible Fluid Drains
15.7	Fuel Flowmeter
15.8	Fuel Flow Limits
16.0	ENGINE CONTROL SYSTEM
16.1	Control Levers
16.1.1	Thrust and Power Lever Position Relationship
16.1.2	Control Lever Torque
16.2	Mechanical Connections
16.3	Control System Adjustment
16.3.1	Idle Speed
16.3.2	Duct Heater Fuel Flow
16.3.3	Airflow
16.3.4	Gas Generator Pressure Ratio
16.4	Environmental Temperatures

TABLE OF CONTENTS (continued)

17.0	IGNITION SYSTEM
17.1	Ignition System Performance
17.2	Ignition System Power Source
18.0	ELECTRICAL SYSTEM
18.1	Electrical Power
18.1.1	External Electrical Power
18.2	Electrical and Electronic Interference
18.3	Ignition Explosion-Proof
18.4	Connectors and Cable
19.0	LIMITING ZONE TEMPERATURES
20.0	STARTING
20.1	In-Flight Starting
20.2	Ground Starting
20.2.1	Unsatisfactory Start
21.0	SHUTDOWN
22.0	WINDMILL OPERATION
22.1	Windmilling Performance
23.0	REVERSE THRUST
24.0	ENGINE NOISE LEVELS
24.1	Sound Calculations
25.0	INSTRUMENTATION
25.1	Provisions
25.2	Special Instrumentation Installation
26.0	TURBINE COOLING SYSTEM
26.1	Turbine Temperature Measurement System
27.0	CUSTOMER REQUIREMENTS
27.1	Drive Power Extractions
27.1.1	Dynamic Loading
27.1.2	Power Takeoff Shaft Speed
27.1.3	Shear Section
27.1.4	Mounting Pad and Power Takeoff (PTO) Shaft Loads
27.1.5	Hydraulic Pump Drive Pads
27.2	Compressor Bleed Air
27.2.1	Quality
27.2.1.1	Seals and Oil Lines
27.2.2	Quantity
28.0	ENGINE TYPE CERTIFICATION TEST
29.0	ACCEPTANCE TEST
29.1	Accuracy
29.2	Fuel and Oil
30.0	QUALITY ASSURANCE PROVISIONS
30.1	Quality Evidence Tests
30.1.1	Magnetic Inspection
30.1.2	Fluorescent Penetrant Inspection
30.1.3	Excepted Parts
30.1.4	Radiographic or Ultrasonic Inspection
30.1.4.1	Radiographic Inspection
30.1.5	Certification of Operators
31.0	PREPARATION FOR DELIVERY
31.1	Preparation for Storage and Shipment

Pratt & Whitney Aircraft
Specification No. 2710

LIST OF ILLUSTRATIONS

Figure No.	Title
1	Maneuver Load Diagram
2	Aerodynamic Loads On Engine Pod

Curve, Sheet No.	Title
1	Estimated Performance - PWA Deck
2	Estimated Engine Operating Envelope
3	Estimated Engine Operating Envelope
4	Estimated Windmilling Restart Envelope
5	Estimated Inlet Total Pressure Recovery
6	Estimated Corrected Airflow Schedule
7	Estimated Windmilling Performance Without Aerodynamic Braking
8	Estimated Windmilling Performance With Aerodynamic Braking
9	Estimated Corrected Total Engine Airflow
10	Estimated Corrected Low Rotor Speed
11	Estimated Corrected High Rotor Speed
12	Estimated Windmilling Performance Without Aerodynamic Braking
13	Estimated Corrected Gross Thrust While Windmilling Without Aerodynamic Braking
14	Estimated Corrected Gross Thrust While Windmilling With Aerodynamic Braking
15	Estimated Variation of Windmilling Performance With High Pressure Compressor Air Bleed
16	Estimated Variation of Windmilling Performance With High Pressure Compressor Air Bleed
17	Estimated Power Available From High Pressure Rotor With Engine Windmilling and No Aerodynamic Braking
18	Estimated Power Required to Overcome Engine Accessory Loads and High Rotor Friction While Windmilling
19	Estimated Variation of Windmilling Performance With Power Extractions
20	Estimated Variation of Windmilling Performance With Power Extractions
21	Estimated Starting Requirements
22	Estimated Engine Acceleration Time
23	Allowable Time at Maximum Fuel Temperature Limit
24	Fuel Inlet Temperature Limits
25	Estimated Allowable Fuel Pressure Fluctuation
26	Estimated Power Lever Operation
27	Narrow Band (CW) Conducted Interference Limits
28	Broad Band and Pulsed CW Conducted Interference Limits
29	Narrow Band (CW) Radiated Interference Limits
30	Broad Band and Pulsed CW Radiated Interference Limits

LIST OF ILLUSTRATIONS (Continued)

Curve, Sheet No.	Title
31	Maximum Allowable Estimated Case Temperatures Vs Engine Length
32	Estimated Maximum Net Reverse
33	Estimated Maximum Net Reverse Thrust
34	Estimated Maximum Net Reverse Thrust
35	Estimated Maximum Augmented Thrust - Sea Level to 45,000 feet
36	Estimated Maximum Augmented Thrust - 55,000 to 80,000 feet
37	Estimated Maximum Augmented TSFC - Sea Level to 80,000 feet
38	Estimated Partially Augmented Performance - 65,000 feet, Mach No. = 2.7
39	Flight Ambient Temperature Envelope
40	Ground Ambient Temperature Envelope

Drawings

Engine Installation Drawing
Allowable Load Drawing
Electrical Installation Connection Diagram

APPENDIX A

Flight Test Status Engines

Figure No.	Title
A-1	FTS Sea Level Endurance Cycle
A-2	FTS Heated Inlet Cycle
A-3	FTS Heated Inlet Cycle

Drawings

Engine Installation Drawing
Allowable Load Drawing
Electrical Installation Connection Diagram

Pratt & Whitney Aircraft

PRATT & WHITNEY AIRCRAFT
Division of United Aircraft Corporation
East Hartford, Connecticut, U.S.A. 06108

Commercial
T.C. No.

Specification No. 2710

MODEL SPECIFICATION
ENGINE, AIRCRAFT, TURBOFAN
PRATT & WHITNEY AIRCRAFT
JTF17A-21B

1.0 SCOPE

1.1 Scope - This specification establishes design and performance requirements for the Pratt & Whitney Aircraft (~~PWA~~) JTF17A-21B turbofan engine to be certificated in Phase ^{IV} of the Supersonic Transport Program. Significant differences in the design and performance of the Phase ~~III~~ ³ Flight Test Status (~~FTS~~) engines for airplane flight testing are noted in Appendix A.

1.2 Specification Performance and Installation Drawing - The Specification Performance is presented in table I and table II and estimated performance throughout the complete engine operating envelope is presented in curve No. S-84, sheet 1. The Installation Drawing forms a part of this specification and is included herein.

2.0 APPLICABLE DOCUMENTS - The following publications were used as a guide in the preparation of this document and form a part of this document to the extent specified herein.

2.1 Government

2.1.1 FAR Part 1 - Federal Aviation Regulations "Definitions and Abbreviations," effective date 15 May 1962.

2.1.2 FAR Part 21 - Federal Aviation Regulations "Certification Procedures for Products and Parts," effective date 21 September 1965.

2.1.3 FAR Part 25 - Federal Aviation Regulations "Airworthiness Standards: Transport Category Airplanes," effective date 29 July 1965.

2.1.4 FAR Part 33 - Federal Aviation Regulations "Airworthiness Standards: Aircraft Engines," effective date 1 February 1965.

2.1.5 FAR AC NO: 33-1 - Federal Aviation Agency Advisory Circular "Turbine-Engine Foreign Object Ingestion and Rotor Blade Containment Type Certification Procedures," effective date 24 June 1965.

2.1.6 FAR Part 45 - Federal Aviation Regulations "Identification and Registration Marking," effective date 20 April 1964.

Pratt & Whitney Aircraft
Specification No. 2710

2.1.7 MIL-STD-210A - "Climatic Extremes for Military Equipment," dated 2 August 1957.

2.1.8 MIL-STD-704 - "Electric Power, Aircraft, Characteristics and Utilization of," dated 6 October 1959.

2.1.9 MIL-E-5007C - "Engines, Aircraft, Turbojet, and Turbofan, General Specifications for," dated 31 December 1965.

2.1.10 MIL-S-7742A - "Screw Threads, Standard Aeronautical," dated 2 December 1959.

2.1.11 MIL-S-8979A - "Screw Threads, Standard Aeronautical," dated 8 December 1965.

2.2 Non-Government

2.2.1 PWA 522 (AS M D-1655-65T, Jet A, A-1) - Pratt & Whitney Aircraft Specification, "Fuel, Commercial Aircraft Turbine Engine," dated 5 November 1965.

2.2.2 PWA 521-B Type II - Pratt & Whitney Aircraft Specification, "Lubricant, Aircraft Turbine Engine," dated 25 June 1963.

2.2.3 SAE ARP 681A - Society of Automotive Engineers, Aeronautical Recommended Practice, "Engine Performance Presentation for Use on High Speed Digital Computers," dated 1 February 1960.

2.2.4 SAE ARP 865 - Society of Automotive Engineers, Aerospace Recommended Practice, "Definitions and Procedures for Computing the Perceived Noise Level of Aircraft Noise," dated 15 October 1964.

2.2.5 SAE ARP 866 - Society of Automotive Engineers, Aerospace Recommended Practice, "Standard Values of Atmospheric Absorption as a Function of Temperature and Humidity for Use in Evaluating Aircraft Flyover Noise," dated 31 August 1964.

2.2.6 SAE AIR 876 - Society of Automotive Engineers, Aerospace Information Report, "Jet Noise Prediction," dated 10 July 1965.

2.2.7 PWA FTDM 208 - Pratt & Whitney Aircraft Technical Design Memorandum, "Design Maintainability Checklist."

2.2.8 PWA FTDM 207 - Pratt & Whitney Aircraft Technical Design Memorandum, "Design Reliability Checklist."

2.2.9 PWA FTDM 210 - Pratt & Whitney Aircraft Technical Design Memorandum, "Design Safety Checklist."

3.0 TYPE AND DESCRIPTION - The JTF17A-21B is a twin-spool, axial-flow, duct heating turbofan engine with a forward multistage fan (also serving as the low pressure compressor) driven by a multistage reaction turbine, and a multistage high pressure compressor driven by a single-stage reaction turbine. This engine is capable of continuous supersonic operation at conditions defined herein. The primary engine exhaust discharges through a fixed convergent-divergent nozzle. The engine incorporates a full length concentric fan discharge duct with a duct heater for augmentation. The duct heater discharges through a modulating, variable-area, convergent exhaust nozzle operated by the engine control and hydraulic systems. The combined primary and duct heater exhaust discharges into a variable-area divergent ejector nozzle which also functions as a thrust reverser and a noise suppressor. Detailed descriptions of engine components shall be presented in the Installation Handbook.

3.1 Installation

3.1.1 Dimension and Installation Drawing - The following drawing forms a part of this specification:

Engine Installation Drawing No. 2129601

3.2 Dry Weight of Engine - The dry weight of the basic engine shall not exceed 9910 pounds. The total dry weight of the engine including special installation items shall not exceed 10,640 pounds. The total dry weight does not include the weight allowance required for cover plates and those brackets supplied with the engine that are to be utilized for the support of airframe equipment. Engine components included in the engine total dry weight are as follows:

- Fuel System Including Gas Generator Control, Duct Heater Control and Fuel Purps
- Lubrication System Including Oil Tank and Fuel/Oil Coolers
- Engine Ignition System Without Power Source
- Variable-Area Duct Heater Exhaust Nozzle Including Control System
- Fuel Inlet Manifold
- Windmilling Brake System (Aerodynamic)
- Reverser-Suppressor Including Control System
- Power Takeoff Provisions Including Inlet Hydraulic Pump Drives Gearbox
- Gas Generator Exhaust Gas Temperature and Pressure Probes
- Provisions for Power Setting Instrumentation
- Secondary Air Ducting Including Control System and Bulkhead
- Supersonic Inlet Support
- Centerline Bend of 6 1/2 degrees Including Conical Reverser-Suppressor
- Turbopump Discharge Air Duct
- Cabin Bleed Manifold
- Anti-Icing Bleed Manifold and Port
- Power Lever Adaptation
- Fan Hub Spinner

Pratt & Whitney Aircraft
Specification No. 2710

Drain Tank, Lines, and Ejector System
Overboard Breather Vent System
Ground Handling Attachments

3.2.1 Weight of Residual Fluids - The estimated weight of residual fluids remaining in the engine after operation and drainage is 40 pounds.

3.3 Engine Mounting - Engine mounting provisions and load limits shall be as specified on the Installation Drawing.

3.4 Requirements

3.4.1 Materials and Processes - Materials and processes used in the manufacture of the engine shall be of a quality consistent with aircraft standards.

3.4.2 Standards

3.4.2.1 Parts - AN, MS, or AS standard parts shall be used unless they are determined by P&WA to be unsuitable for the purpose, and shall be identified by their standard part numbers.

3.4.2.2 Design Standards - MS, AND, and industry design standards shall be used unless they are determined by P&WA to be unsuitable for the purpose.

3.4.3 Parts List - The parts list for the engine which satisfactorily completes the certification test as modified by approved changes shall constitute the parts list for engines of the same model to be delivered.

3.4.4 Interchangeability - All parts having the same manufacturer's part number shall be functionally and dimensionally interchangeable with each other with respect to installation and performance, except that matched parts or selective fits will be permitted where required.

3.4.5 Accessibility - Those parts of the engine requiring line maintenance checking, adjustment, draining, or replacement shall be made accessible without engine teardown or removal of major parts, components or accessories as shown on the Installation Drawing.

3.4.6 Maintainability, Reliability, and Safety

3.4.6.1 Maintainability - The engine shall be designed for ease of servicing and maintenance in accordance with 2.2.7.

3.4.6.2 Reliability - Engine reliability considerations shall be as guided by 2.2.8.

3.4.6.3 Safety - Engine safety considerations shall be in accordance with 2.2.9.

3.4.7 Engine Expansion Dimensions - Engine dimensional changes resulting from temperature increases between room and operating temperatures are as shown on the Installation Drawing.

3.4.8 Flight Maneuver Forces - The engine supports shall withstand without permanent deformation the conditions specified on the maneuver load diagram as shown on figure 1. The engine shall operate satisfactorily when exposed to the vertical, side, and thrust loads as shown on figure 1 and pitch velocity of 1.0 radian per second and yaw velocity of 0.5 radian per second, respectively.

3.4.9 Ground Handling - The engine shall have provisions for ground handling attachments. The attachment provisions shall be designed as follows:

- a. Vertical loading - 4 "g"
- b. Side loading - 2 "g"
- c. Fore to aft loading - 1.5 "g"

3.4.10 Engine Inlet Flange Design Load - The engine inlet flange design load shall be as specified on the Installation Drawing.

3.4.11 Containment and Rotor Structural Integrity - The engine shall be designed for rotor blade containment to meet the requirement of Paragraph 33.19 of Reference 2.1.4 and compliance shall be specified in the engine type certificate.

3.4.12 Flammable Fluid Systems - All external lines and fittings which convey flammable fluids shall be fireproof as defined in 2.1.1. Each separable joint or connection shall be designed or shielded so that the likelihood of leakage causing a fire hazard is remote.

3.4.13 Engine Connections - All electric, fluid and pneumatic connections to which the airframe manufacturer will attach are defined on the engine Installation Drawing.

3.4.14 Connection Identification - Insofar as is practical, the engine shall be permanently marked to indicate all airframe connections shown on the Installation Drawing for instrumentation, electrical, fluid and pneumatic connections. Similar fluid connections located in close proximity to each other shall be made physically noninterchangeable.

3.4.15 Engine Mounted Airframe Accessories

3.4.15.1 Use of Integral Oil Systems for Accessories - The integration of accessory oil systems with that of the engine shall not be acceptable.

Pratt & Whitney Aircraft

Specification No. 2710

3.4.15.2 Engine-Supplied Support Brackets for Airframe Accessories - Engine-supplied support brackets for airframe accessories shall be as shown on the Installation Drawing. Support of airframe equipment shall be coordinated with and agreed upon by P&WA.

3.4.15.3 Cover Plates - Cover plates for covering all accessory drive openings where the accessory is not mounted for engine shipment shall be supplied with each engine. Suitable provisions for covering or plugging all other connection openings shall be made. Cover plates suitable for flight operation shall be provided on drive pads and connecting points which are not used.

3.4.16 Useful Life - The engine shall be designed for a useful life, including repair, consistent with an airplane normal service life expectancy of at least 50,000 hours. The design objective for the basic engine shall be a useful life, with repair, in excess of 5000 hours. P&WA shall undertake the design and development of improved components or parts and/or repair procedures for the components or parts, as shown to be required by airline service.

3.4.17 Identification of Product - The identification data applied to the engine data plate shall be in accordance with 2.1.6 as follows:

Manufacturer's Name or Trademark

Model Designation*

Serial No.*

Installation Arrangement*

Takeoff Rating*

Fuel*

Type Certificate Number*

Production Certificate Number*

*Applicable data to be entered by P&WA.

Equipment, assemblies and parts shall be marked for identification in accordance with P&WA standard procedures.

4.0 MASS MOMENT OF INERTIA OF ROTATING PARTS - The estimated effective mass moments of inertia of the engine rotors about their axes are 30.0 slug-feet squared for the low rotor and 21.5 slug-feet squared for the high rotor. The maximum effective mass moment of inertia of the engine at the power takeoff accessory drive is as shown on curve No. S-84, sheet 21.

5.0 VIBRATION - The engine shall be designed and constructed to function throughout its operating range without inducing excessive stress in any of the engine parts because of vibration. The engine unbalance shall not cause an engine case displacement greater than + 3 mils. This vibration requirement is applicable to engines operating with specified flight weight components installed. Installed vibration characteristics of the engine-nacelle combination must be established by the airframe manufacturer and be coordinated with P&WA.

5.1 Airframe Vibration Testing with Installed Engines - If the airframe manufacturer deems it necessary to shake the airframe with the engine installed during airframe stress and fatigue tests, or during tests to establish vibration characteristics, it will be necessary to rotate both engine rotors to prevent brinelling of the bearings. Rotor speeds may be achieved by turning the high rotor with a hydraulic starter or the low rotor with an air stream directed on either the turbine or fan blades. The determination of safe rotor speeds must be coordinated with and agreed upon by P&WA.

6.0 ENGINE PERFORMANCE - The specified ratings are attainable on a P&WA test stand using a P&WA bellmouth inlet at 1962 U.S. Standard Atmosphere (Geometric) conditions at the engine inlet, with the fuel specified in 2.2.1, without compressor air bleed or load on accessory drives other than that required for continuous engine operation and with correction to engine performance for any bellmouth total pressure loss.

6.1 Performance Ratings - The specified engine thrusts and thrust specific fuel consumptions (TSFC) include the effects of the reverser-suppressor. Performance is based on a cylindrical outside reverser-suppressor with external flows parallel to the reverser-suppressor centerline at free stream flow conditions, accounting for boundary layer growth at the blow-in door entry station and external pressure drag on the reverser-suppressor tailfeathers. This performance is based on a temperature corrected secondary airflow (W_{sc} defined below) of 2% except for reverse thrust which is based on zero secondary flow. A minimum of 2% corrected flow is required at all operating conditions when the tertiary and the reverse doors are closed.

$$W_{sc}\% = \frac{W_s}{W_{ge} + W_{gd}} \left[\sqrt{\frac{T_{t2} + \Delta T_s}{W_{ge} T_{t9} + W_{gd} T_{td}}} \right] \times 100$$

where:

- W_s = secondary airflow, lb/sec
- W_{ge} = total gas generator gas flow at nozzle throat, lb/sec
- W_{gd} = total duct gas flow at nozzle throat, lb/sec
- T_{t2} = compressor inlet total temperature, °R
- ΔT_s = secondary stream temperature rise, °R
- T_{t9} = total temperature at gas generator nozzle throat, °R
- T_{td} = total temperature at duct nozzle throat, °R

Pratt & Whitney Aircraft
Specification No. 2710

The specified reverse thrust is attainable at sea level static test stand conditions when reingestion of exhaust gases is not experienced, and without special restrictive provisions for reverse targeting. The specified value is based upon a reverse effective flow area over 192 degrees of circumference and a mean gas discharge angle of 20 degrees or less with the exhaust nozzle centerline.

6.1.1 Guaranteed Standard Day Calibration Stand Performance at Sea Level - The guaranteed standard day calibration stand performance at sea level is as shown in table I. Engine calibrations will be demonstrated by calibrations with the reverser-suppressor and P&WA bellmouth.

Table I. Guaranteed Standard Day Calibration Stand Performance at Sea Level

Rating	Net Thrust (Min), lb (4)	TSFC (Max), lb/hr/lb (6)	Estimate of Measured Exhaust Gas Temp. (Max), °F(°C) (5)	Estimated Airflow, lb/sec	Estimated Engine Rotor Speed, rpm N ₁ (5) N ₂	
Takeoff (1)						
Augmented	51,000	1.77	1515 (823.9)	687	6500	8200
Nonsaugmented	38,300	0.74	1515 (823.9)	687	6500	8200
Maximum (2)						
Augmented	61,000	1.77	1515 (823.9)	687	6500	8200
(3)						
Maximum Reverse	15,300	--	--	--	--	--

- (1) Takeoff Rating - This rating is intended for takeoff use only and is time limited to 5 minutes. The specified takeoff rating is the maximum takeoff thrust available at standard day temperatures and below.
- (2) Maximum Rating - This rating is primarily intended for climb and acceleration with augmentation from zero to full duct heat. This rating is time limited to 30 minutes. This rating is also available for emergency use at the discretion of the pilot and is authorized as a maximum continuous rating under emergency conditions.
- (3) The specified maximum reverse thrust is as measured along the exhaust nozzle centerline and is time limited to 30 seconds.
- (4) Forward thrust is measured along the exhaust nozzle centerline.
- (5) Subject to change prior to engine certification.
- (6) Based on a fuel having a lower heating value of 18,400 Btu/lb.

6.1.2 Guaranteed Steady-State Performance Ratings at Standard Altitude Conditions - The guaranteed steady-state performance ratings at standard altitude conditions are as shown in table II. Demonstration will be made using an engine assembled substantially in accordance with the production parts list on a P&WA approved test stand using the specified fuel and standard calibration equipment and methods. The substantiation of any guaranteed point where the test conditions exceed the capability of the laboratory will be by calculations from test data obtained at test conditions that lie within the capacity of the laboratory.

Engine performance will be demonstrated by calibrations without the reverser-suppressor. Simulated flight Mach number and altitude conditions will be accomplished by setting measured test engine inlet total pressure and total temperature corresponding to that calculated for the 1962 U.S. Standard Atmosphere (Geometric) and the specified inlet ram recovery. Engine airflow will be measured using a standard ASME orifice to permit the calculation of ram drag and gross thrust. Measurements of engine discharge pressures, temperatures, and areas, combined with ambient back pressure for the simulated altitude, permit calculation of gross thrust assuming an ideal expansion process to ambient pressure. Reverser-suppressor gross thrust coefficients (C_{fp}) determined from isolated scale model tests in a free flow field with a uniform and parallel flow forward of the tertiary doors, will be applied to the ideal expansion gross thrust to obtain the actual gross thrust.

Net thrust is determined by subtracting the calculated ram drag (of the engine plus secondary airflows) from the calculated gross thrust. The specified TSFC is obtained by dividing the measured engine fuel flow by the net thrust.

For the purpose of practical demonstration, the altitude performance will be met if substantiated within the precision of the altitude laboratory equipment.

6.2 Estimated Engine Performance - Estimated engine performance and data are shown on curve No. S-84, sheets 1 through 40. Information supplied on these curves is based upon no air bleed and no power extraction over and above that required for continuous operation of the engine and accessory drives, except as specified.

A card deck program, reference curve No. S-84, sheet 1, shall be provided which is capable of running on a high-speed computer mutually agreed upon by P&WA and the airframe manufacturer. This program will define estimated engine performance, representing maximum fuel flow, minimum thrust and average values for all other items, and will be consistent with the engine performance specified in table I and table II. Idle thrust may be average. The program shall be capable of generating data at any power setting from idle to takeoff at any altitude, Mach number, or ambient temperature within the engine operating envelope. The program shall be capable of making corrections for horsepower extraction, inlet pressure recovery, and air bleed.

Pratt & Whitney Aircraft
Specification No. 2710

Table II. Guaranteed Steady-State Performance Ratings at Standard Altitude Conditions

Power Setting	Pressure Altitude, ft	Mach No.	Ram Recovery	Net Thrust (Min), lb (C)	TSPC (Max), 1 st /hr/lb (6)	Estimate of Measured EGT (Max), °F (°C) (4)	Airflow, lb/sec ± 3% (4)	Estimated Rotor Speed, rpm (4)	Estimated Secondary Airflow, lb/sec (4) (5)	Estimated Secondary Stream Total Pressure, Pts, Psia (3) (4)
								N ₁ N ₂		
Maximum Augmented	45,000	1.2	0.991	19,900	1.86	1525(829.4)	250(4)	6510 8080	12.5	3.2
Cruise Partially Augmented	65,000	2.7	0.846	15,200	1.61	1450(787.8)	318(2)	5520 8250	10.0	2.8
Cruise Nonaugmented	36,150	0.8	1.0	4,250	0.99	850(454.4)	220(4)	4980 6800	6.1	3.3
Part Power	15,000	0.4	1.0	4,490	0.97	745(396.1)	298(4)	4150 6360	7.7	8.3

- (1) Thrusts are along the exhaust nozzle centerline.
- (2) Cruise airflow steady-state tolerance does not include tolerances due to inlet flow distortion.
- (3) At the specific secondary airflow.
- (4) Subject to change prior to engine certification.
- (5) Secondary air at engine face.
- (6) Based on a fuel having a lower heating value of 18,400 Btu/lb.

Pratt & Whitney Aircraft
Specification No. 2710

Unless otherwise specified, all engine performance estimates are based upon the following:

- a. Ambient conditions in accordance with 1962 U.S. Standard Atmosphere (Geometric).
- b. Inlet Total Pressure Recovery at the engine inlet as defined on curve No. S-84, sheet 5.
- c. Radial and circumferential overall pressure distortion at the inlet as defined in section 10.0(a).
- d. Fuel with a lower heating value of 18,400 Btu/lb.
- e. No power extraction or compressor air bleed over and above that necessary for operation of engine and accessory drives.
- f. Minimum effective flow area for reverser-suppressor tertiary air induction of 12.0 square feet over a minimum circumference of 236 degrees.
- g. Thrusts are along the exhaust nozzle centerline. Performance is based upon a cylindrical outside reverser-suppressor with external flow parallel to the reverser-suppressor centerline at free stream flow conditions accounting for boundary layer growth at the blow-in door entry station.

6.3 Flight Conditions - The engine shall function satisfactorily under the following flight conditions:

- a. Level position (horizontal) with the engine inclined (roll) 20 degrees to either side.
- b. Level position (horizontal) with the engine inclined (roll) 45 degrees to either side for 30 seconds.
- c. Zero to 15 degrees below horizontal (nose down) with up to 20 degrees inclination on either side.
- d. Zero to 30 degrees above horizontal (nose up) with up to 20 degrees inclination on either side.
- e. Flight operation under negative 1 "g" flight conditions for 10 seconds.
- f. Flight operation under zero "g" flight conditions for 5 seconds.

6.4 Atmospheric Liquid Water - The engine shall operate satisfactorily throughout the flight operating envelope under conditions of idle to maximum thrust at levels up to 5% of the total airflow weight in the form of water (liquid and vapor) evenly distributed as it enters the engine inlet.

6.5 Ambient Temperature Conditions - The complete engine shall perform satisfactorily under ambient temperature conditions defined by curve No. S-84, sheets 39 and 40.

7.0 ENGINE OPERATING ENVELOPE - When P&WA recommended procedures are complied with, the engine shall operate satisfactorily within the inlet total temperature, total pressure and time limits as shown on curve No. S-84, sheet 2. The corresponding pressure altitude and Mach number envelope for standard day conditions is shown on curve No. S-84, sheet 3.

Pratt & Whitney Aircraft
Specification No. 2710

8.0 THRUST TRANSIENTS

8.1 Stability - Under steady-state operating conditions without augmentation, thrust oscillation shall not exceed $\pm 5\%$ of the thrust available at that particular power lever position and flight condition, but in no event shall the thrust oscillation exceed $\pm 1\%$ of the maximum nonaugmented thrust available. During steady-state operation with any amount of augmentation up to maximum, the engine thrust oscillation shall not exceed $\pm 1\%$ of the maximum augmented thrust available at that condition.

8.2 Response - For power lever movement of 1 second or less, the time required to safely accomplish the following transients on a standard day with no bleed or power extraction shall not exceed the tabulated values, from sea level to 6000 feet altitude:

Transient	Time, sec
Idle to 75% maximum nonaugmented rating:	6.0
Idle to 95% maximum nonaugmented rating:	8.0
Idle to 95% maximum augmented rating:	8.5
30% maximum nonaugmented rating to 95% augmented rating:	5.0
Maximum augmented rating to 95% full reverse:	6.0

The relationship of engine high rotor speed versus time is shown on curve No. S-84, sheet 22.

9.0 PRESSURE AND TEMPERATURE CHANGE

9.1 Inlet Pressure Transients - The engine is estimated to be capable of experiencing an occasional reduction in stabilized $P_{t2 \text{ Avg}}$ of 60% in 1/20 of a second for a maximum of 3 seconds without any direct damage provided that the distortion limits specified herein are not exceeded. Rapid changes of pressure are not recommended and would be expected to cause adverse engine operation including stall and/or flameout.

The engine is estimated to be capable of experiencing an occasional variation of stabilized $P_{t2 \text{ Avg}}$ of +15% and -60% at a frequency range of up to 5 cycles per second for a maximum of 1 minute without any direct damage provided that the distortion limits specified herein are not exceeded. Rapid changes in pressure are not recommended and would be expected to cause adverse engine operation including stall and/or flameout.

9.1.1 Minimum Exhaust Pressure - The engine inlet air total pressure divided by the external pressure at the exhaust nozzle shall not be less than 1.0 at high rotor speeds less than 6500 rpm in flight.

9.2 Inlet Temperature Rate of Change

9.2.1 Normal - The maximum continuous rate of inlet temperature change which the engine can withstand without performance degradation is 1.5°F (0.8°C) per second. The engine can withstand a rate of inlet temperature change not exceeding 5°F (2.8°C) per second for a total of 40°F (22.2°C) to account for atmospheric temperature gradients.

9.2.2 Emergency - Under emergency conditions, the maximum continuous rate of inlet temperature change shall not exceed 3.0°F (1.7°C) per second. It is anticipated that performance degradation will result from engine operation which exceeds the limits in 9.2.1 but does not exceed the emergency limit.

10.0 INLET AIR PRESSURE DISTORTION - The estimated capability of the engine to withstand inlet air pressure distortion is described below where terms are defined as follows:

P_{t2} Avg = Average area weighted engine inlet total pressure

P_{t2} Max = Maximum engine inlet total pressure measured using instrumentation as recommended by P&WA

P_{t2} Min = Minimum engine inlet total pressure measured using instrumentation as recommended by P&WA

$$\text{Percent Overall Distortion} = \frac{P_{t2} \text{ Max} - P_{t2} \text{ Min}}{P_{t2} \text{ Avg}} \times 100$$

The Percent Overall Distortion shall be evaluated as a time dependent quantity and is defined as the maximum instantaneous value of the quantity.

Allowable circumferential and radial distortion limits are dependent on the distribution and extent of the distortion. Accordingly, compatibility between engine and inlet shall be determined and agreed upon between P&WA and the airframe manufacturer based on detailed analysis of flight test data and the estimates below must be considered as preliminary and subject to change. Until engine development confirms that adverse effects of distortion within these limits on engine performance and component durability are tolerable, flight operation at these distortion levels cannot be recommended.

- a. For continuous operation, the estimated allowable overall inlet air pressure distortion limits as defined in 10.0 shall be approximately 13% except within 1/2 inch at the inside diameter and outside diameter of the flow annulus. The effect of distortion on engine performance within this limit may be considered negligible.
- b. It is estimated that overall distortion of 25% excluding the area within 1/2 inch of the duct walls will not so adversely affect engine operation as to precipitate engine stall or flameout.
- c. If all P&WA operating recommendations are followed, no direct engine damage would be expected as a result of inlet distortion in excess of above limits, if this distortion does not exceed a 10-second duration.

Best Available Copy

11.0 INLET ANTI-ICING - The engine shall be capable of operation throughout the flight power range without accumulation of ice on the engine air induction system such as to adversely affect engine operation or cause a serious loss of thrust in continuous maximum and intermittent maximum icing conditions as defined in Appendix C of 2.1.3.

12.0 FOREIGN OBJECT INGESTION - The engine shall comply with the requirements of 2.1.5 with respect to foreign object ingestion. Demonstration of sheet ice ingestion shall be limited to single sheets of ice 1/2-inch thick and 144 square inches in area, and a single sheet of ice 1 inch by 2-1/2 inches by 30 inches having a specific gravity of 0.85.

13.0 EXHAUST SYSTEM

13.1 Secondary Airflow - Secondary airflow is required for reverser-suppressor cooling when the tertiary air doors are closed to control the expansion of the fan exhaust stream. The secondary air is supplied to and routed around the engine in accordance with the requirements of 6.1.

14.0 LUBRICATION SYSTEM - The lubrication system is a self-contained engine system which does not require an airframe supplied input.

14.1 Oil Type - The oil type is as specified in 2.2.2.

14.2 Oil Consumption - The oil consumption shall not exceed 0.25 gallons per hour as measured over a 10-hour period.

14.3 Oil Pressure and Temperature Limits - The operating oil pressure at maximum rated thrust shall be 45 ± 5 psi (relative to internal engine scavenge compartment) at 250°F (121.1°C) oil temperature. The oil pressure and temperature indicator ranges required for the cockpit indicators are 0 to 120 psi and 0 to 235°C, respectively. The maximum transient oil temperature during normal operation shall be 360°F (182.2°C) at the location indicated for oil temperature on the Installation Drawing. During windmilling operation up to 25% of maximum rated engine rotor speed, the maximum transient oil temperature shall not exceed 400°F (204.4°C) for 3 minutes and the oil pressure must be positive. Low temperature starting and operation is limited to an oil temperature corresponding to an oil viscosity of 10,000 centistokes.

14.4 Oil Quantity - The oil reservoir shall contain usable oil sufficient for 10 hours of engine operation.

14.5 Oil Tank - The oil tank shall contain the following features:

- a. Fill System
 - (1) Pressure (remote fill)
 - (2) Gravity-fill port with scupper drain (at tank)
- b. Quantity Measurements
 - (1) Mounting boss for remote oil quantity transmitter
 - (2) Dip stick and cap
- c. Scavenge Oil Deaerator (with tank)
- d. Drain Valve
- e. Strainers on Supply Ports (pressure and gravity)
- f. Magnetic Chip Detector.

14.6 Oil Flow Interruption - The engine shall operate continuously with no detrimental effects during and after a period of 10 seconds of negative "g" operation and/or 30 seconds of low oil pressure indication caused by maneuvers.

14.7 Drive Pad Lubrication - The power takeoff, hydraulic pump, and tachometer pads shall be pressure lubricated by the engine lubrication system.

15.0 FUEL - The engine shall function satisfactorily throughout the operating envelope when supplied with aviation kerosene meeting the requirements of the fuel specified in 2.2.1 at the engine fuel inlet.

15.1 Fuel Temperature Limits - The temperature of fuel provided at the engine inlet connection must be between the limits shown below for the condition specified. The allowable time at the maximum fuel temperature limits is shown on curve No. S-84, sheet 23.

Condition	PWA 522 (Jet A, A-1) Limits
Ground Starting	Minimum - Temperature corresponding to a fuel viscosity of 12 centistokes. Maximum - Curve No. S-84, sheet 24.
All other conditions	Minimum - 10°F (5.6°C) above fuel freezing point. Maximum - 260°F (126.7°C) or as shown on curve No. S-84, sheet 24.

The temperature rate of change at the engine fuel inlet connection shall not exceed 50°F (27.8°C) per minute. Provisions have been made on the engine to measure pressure drop across the fuel filter as an indication of ice accumulation. The engine is not equipped with a fuel heater. If detailed parameters affecting fuel heating rates determine the need for a heater or a larger filter, an engine-supplied fuel heater or larger filter may be negotiated with P&WA.

15.2 Fuel Pressure Limits - Fuel pressure, including cyclic and random pressure fluctuations, at the engine connections must be maintained at not less than 5 psi above true vapor pressure of the fuel and not greater than 50 psig and with a vapor/liquid ratio of zero. Pressure fluctuations at the engine fuel pump inlets shall be within the limit of curve No. S-84, sheet 25.

Under emergency conditions, with tank-mounted boost pumps inoperative, the engine shall operate for limited periods under the inlet conditions shown in table III, provided the true vapor pressure of the fuel does not exceed 0.5 psia at 175°F (79.4°C) and 2.5 psia at 250°F (121.1°C) and the vapor/liquid ratio at the engine inlets does not exceed 0.30.

Pratt & Whitney Aircraft

Specification No. 2710

Table III. Fuel Pressure Limits

Condition	Power	Altitude, feet	Mach No.	Time, Hours	Fuel Temp., °F (°C)	Fuel Pressure at Inlet Connection, psi
1	Maximum Augmented	0-8,000	0 to 0.3	0.03	140 (60)	4.65 below ambient
2	Maximum Nonaugmented	0-15,000	0.45 at S.L. 0.60 at 15,000 ft	0.03	140 (60)	3.75 below ambient
3	Part Power	36,150	0.8	4.00	140 (60)	1.3 below ambient
4	Idle	0-73,000	0 to 2.7	0.50	140 (60)	0.20 below ambient

The engine fuel system shall be capable of priming itself and starting within 5 minutes after 10-second fuel starvation when subjected to the following conditions:

- a. Dry lift of 2 feet.
- b. 20,000 feet fuel tank altitude.
- c. 140°F (60°C) fuel temperature.
- d. A fuel line volume of 14 U.S. gallons maximum between the fuel pump inlet and the fuel pump supply.
- e. Fuel as specified in 2.2.1.

15.2.1 Fuel System Design Pressure - The engine fuel system shall be designed to withstand a maximum fuel pressure of 170 psig applied at the engine inlet connection with the engine shutdown.

15.3 Fuel Recirculation - The engine will provide a connection for the recirculation of fuel to the aircraft tanks. The location and details of this connection shall be defined on the Installation Drawing. During operation where recirculation is not required, a continuous flow of 500 pounds per hour (pph) may be allowed for recirculation to prevent stagnation in the aircraft system. The pressure, flow, and temperature requirements at the engine fuel recirculation connection are shown on the Installation Drawing.

15.4 Fuel Cleanliness - Fuel delivered to the engine must meet the requirements of 2.2.1 and be free of all solid contamination larger than that which will pass through a 200-mesh screen and be essentially free of solid contamination of a smaller size.

15.4.1 Fuel Contamination - The use of fuel contaminated to the extent of 8 grams of foreign matter per 1000 gallons shall not inhibit satisfactory engine running for a minimum of 10 hours. This foreign matter shall be considered to consist of not less than 68% SiO₂ and shall have a particle size analysis as follows:

Particle Size, Microns	Percent of Total by Weight
0-5	39 ± 2
5-10	18 ± 3
10-20	16 ± 3
20-40	18 ± 3
Over 40	9 ± 3
Through a 200-mesh screen	100

15.4.2 Fuel Filters - The fuel filters shall be provided with the engine. Each shall be of sufficient capacity to permit a cumulative fuel flow equivalent to a minimum of 10 hours of continuous engine operation at maximum nonaugmented sea level thrust. This time is based on fuel contaminated as specified in 15.4.1 where the contaminated fuel has first passed through a 200-mesh screen prior to entering the engine fuel system.

15.5 Fuel Leakage - For normal operation, there shall be no leakage from any part of the engine except at the drains provided for this purpose. A drain tank shall be provided on the engine to collect leakage from engine accessory pad drains and to collect the fuel discharged from the fuel manifold and combustion chamber during start or shutdown. The tank shall have a minimum capacity for 1 normal shutdown and 2 false starts. Suitable ports shall be provided for both overflow and vent connections. The shape and location of the drain tank and size and location of the ports shall be coordinated with the airframe manufacturer. The drain tank shall be of fireproof construction. An ejector shall be incorporated to discharge the drain tank contents into the engine exhaust system.

15.6 Combustible Fluid Drains - Provisions shall be made for automatically clearing the combustion areas of combustible fluids after each false start and for preventing excess combustible fluids from entering the combustion areas after shutdown with the engine in a level position, 15 degrees nose up, and 20 degrees nose down. Provisions shall also be made for clearing all vent areas and other pockets or compartments where combustible fluids may collect during or subsequent to operation of the engine.

15.7 Fuel Flowmeter - The provision for installation of fuel flowmeters is noted on the Installation Drawing.

15.8 Fuel Flow Limits - The maximum fuel flow shall be 120,000 pph at maximum rating and takeoff operating conditions. The minimum fuel flow limit shall be 1200 pph at idle rating and cruise operating conditions.

16.0 ENGINE CONTROL SYSTEM - The fuel and exhaust nozzle control incorporates the gas generator and duct heater controls in a unitized assembly. The unitized control has dual input levers. The power lever controls engine thrust, speed, and turbine inlet temperature from Full Reverse to Idle to Maximum Augmentation. The shutoff lever provides for engine shutdown and starting by closing or opening the fuel shutoff valve. Fuel is metered to the gas generator to set the desired thrust as a function of power lever position, high compressor rotor speed, burner pressure and engine inlet temperature. Fuel is metered to the duct heater to set the desired thrust augmentation as a function of power lever position, burner pressure, and engine inlet temperature. The duct heater exhaust nozzle area is positioned to control total engine airflow over part of the engine operating range as shown on curve No. S-84, sheet 6. Remote manual power and airflow setting is provided to allow vernier adjustment. If engine speed exceeds a specified value, the gas generator fuel control automatically reduces fuel flow to prevent turbine overtemperature and damaging engine rotor speeds. Low rotor overspeed is limited by automatic derichment of gas generator fuel flow. The control system also provides reverser interlocks to: (1) prevent engine power requests not consistent with the reverser position; and, (2) return the engine power to idle if the reverser inadvertently moves from the requested position.

The control system also provides the following auxiliary functions:

- a. Positions the compressor stator vanes.
- b. Positions the compressor bleeds.
- c. Positions the reverser-suppressor.
- d. Provides fuel shutoff.
- e. Provides duct heater ignition.

The engine-driven gas generator fuel pump incorporates a centrifugal boost stage and a gear stage. A pressure relief valve is incorporated to bypass the boost stage in the event of pump drive malfunction, and a pressure relief valve is included from gear stage discharge to gear stage inlet to prevent fuel system overpressurization. The duct heater fuel pump is a centrifugal pump driven by a turbine driven by high compressor discharge air, which is modulated by a pump controller in response to servo pressure signals from the unitized control. The turbine exhaust air passes through a vortex venturi which aerodynamically limits pump overspeed. The engine-driven hydraulic pump is a variable flow, constant pressure, piston-type pump.

16.1 Control Levers - A single power lever shall be provided on the engine to modulate thrust. The power lever shall have a total travel and dwell bands as shown on curve No. S-84, sheet 26. Neither the control system nor the power lever shall be self-energizing in any direction. A separate lever shall be provided for fuel shutoff and for arming the windmill aerodynamic brake. The shutoff lever modes shall be as shown on the Installation Drawing. There shall be stops and indexing provisions for the power lever and the shutoff lever as shown on the Installation Drawing.

Pratt & Whitney Aircraft
Specification No. 2710

16.1.1 Thrust and Power Lever Position Relationship - The design relationship between thrust and power lever position shall be of the fully modulated type, free of abrupt changes, and essentially linear (except when the bleed valve operates), with an instantaneous thrust increase of not more than 4% when augmentation is initiated or terminated. The design relationship between reverse thrust and reverse thrust power lever position shall be free of abrupt changes and essentially linear.

16.1.2 Control Lever Torque - The torque required for advancing or retarding the power lever shall not exceed 25 pound-inches at the control external attachment point with the engine at idle or above. The torque required to operate the shutoff lever shall not exceed 20 pound-inches at the control external attachment point with the engine at idle or above. Below idle, the torque required for advancing or retarding the power lever or the shutoff lever shall not exceed 50 pound-inches. The reverser interlock mechanism shall be capable of applying 300 pound-inches to the power lever, including control torque requirements, when returning it to the idle position.

16.2 Mechanical Connections - The maximum loads that may be applied to any control system mechanical connection are as shown on the Installation Drawing.

16.3 Control System Adjustment - External control system adjustments shall be clearly marked, accessible, and adjustable with the engine running. All other adjustments shall be protected to discourage tampering. The adjustments shall include the following.

16.3.1 Idle Speed - The idle speed shall be adjustable within a range of at least $\pm 5\%$ of the specified value with reference to engine operating characteristics on the ground.

16.3.2 Duct Heater Fuel Flow - The maximum duct heater fuel flow shall be adjustable within a range of $\pm 5\%$ with reference to engine operating characteristics on the ground.

16.3.3 Airflow - Remote adjustment of airflow for optimum engine inlet matching is provided.

16.3.4 Gas Generator Pressure Ratio - Remote adjustment of engine pressure ratio is provided to allow close setting of engine power in the duct heater regime.

16.4 Environmental Temperatures - The engine components shall operate satisfactorily under the environmental temperatures anticipated at the following conditions:

- a. Continuous operation with surrounding air at the maximum ram temperature of 600°F (315.6°C).
- b. In-flight shutdown from the most adverse conditions and continued soaking with surrounding air at the maximum ram temperature of 600°F (315.6°C) provided fuel recirculation is maintained.

Pratt & Whitney Aircraft
Specification No. 2710

- c. Ground shutdown with surrounding air at the standard hot day conditions.
- d. Transient operation for the time limit specified on curve No. S-84, sheet 2 with surrounding air at a ram temperature of 650°F (343.3°C).

17.0 IGNITION SYSTEM - The ignition system consists of 2 fuel-cooled, hermetically sealed exciter packages each containing 2 independent exciter circuits for 1 gas generator igniter and 1 duct heater igniter. The ignition system is a capacitor discharge, 4 joule per spark at 3 kilovolts (with boost capability), intermittent duty, alternating current powered system.

17.1 Ignition System Performance - The engine start ignition system shall be capable of releasing sufficient energy for all ground and air starting requirements. The gas generator circuit shall supply a minimum of 1 spark per second and the duct heater a minimum of 5 sparks per second at the minimum voltage specified herein. The gas generator ignition system shall be capable of discretionary continuous operation.

17.2 Ignition System Power Source - The minimum power source and the maximum input to each exciter circuit shall be as specified on the Installation Drawing.

18.0 ELECTRICAL SYSTEM

18.1 Electrical Power - In the event of loss of external power while in operation, the engine shall be electrically self-sufficient. At all engine speeds at or above idle, the engine shall continue to operate safely. Supersonic inlet anti-icing and other systems not critical for operation may be inoperative. Electrical equipment shall operate with power defined in 2.1.8.

18.1.1 External Electrical Power - External electrical power requirements shall be as specified on the Installation Drawing.

18.2 Electrical and Electronic Interference - Electrical and electronic components shall not cause interference beyond the limits specified on curve No. S-84, sheets 27 through 30. These components shall not be susceptible to interference generated by other electrical and electronic sources within the limits specified in table IV.

Table IV. Electrical and Electronic Interference

	Antenna	Frequency Range	Voltage (5)	
Conducted interference	- - - - -	(rf) 0.15 to 1,000 mc (1)	0.1	(3)
		(af) 50 to 15,000 cps (2)	3.0	
Radiated interference (4)	41 inch rod	0.10 to 25 mc	0.1	(3)
	35 mc dipole	25 to 35 mc	0.1	(3)
	tuned dipole	35 to 1,000 mc	0.1	(3)

Pratt & Whitney Aircraft
Specification No. 2710

- (1) Applicable only to ungrounded line voltage power input points.
- (2) Applicable only to ungrounded dc line voltage power input points.
- (3) Modulated 30% at 400 to 1,000 cycles or any special form of modulation to which the equipment is vulnerable.
- (4) Antenna placed 1 foot from electrical or electronic components.
- (5) Value of open circuit from 50 ohm source impedance.

18.3 Ignition Explosion-Proof - All electrical components shall be ignition explosion-proof in order not to ignite any explosive mixture surrounding the equipment.

18.4 Connectors and Cable - At a temperature of -50°F (-45.6°C) it shall be possible to connect or disconnect electrical connectors and to flex electrical conductors, as necessary for routine maintenance, without damage to these items.

19.0 LIMITING ZONE TEMPERATURES - Airframe engine nacelle design shall be such that engine case temperatures shall not exceed those specified on curve No. S-84, sheet 31. The engine shall not require blast air cooling of the nacelle area. All components within this zone shall, by basic design, be suitable for operation (ground shutdown, flight shutdown, and all flight conditions) without added ram cooling, but with normal nacelle leakage unless local temperatures due to external heat sources, other than from the engine and its components, exceed the limits in 16.4.

20.0 STARTING - The fuel flow required for engine lightoff and acceleration to idle shall be automatically controlled when the fuel control shutoff lever is placed in the starting position with the power lever in the idle position. Automatic actuation of the starter or ignition system will not be provided. Appropriate starting torque shall be provided by a suitable airframe mounted starter through the power takeoff drive to the high speed rotor (N_2). The in-flight and ground starting requirements are as follows.

20.1 In-flight Starting - Starter assistance is not required to satisfactorily start the engine within the flight conditions shown on curve No. S-84, sheets 2 and 4 provided:

- a. That the fuel temperature requirements of 15.1 are met.
- b. That the fuel pressure requirements of 15.2 are met.
- c. That the electrical power requirements of 18.0 for starting are met.
- d. That there is no compressor air bleed or power extraction other than that required for continuous engine operation.

In-flight starting may be obtained at ram pressure ratios below the minimum ram pressure ratio line on the windmilling restart envelope by using engine starter assistance whenever the starter arrangement permits.

20.2 Ground Starting - The engine shall start satisfactorily in 30 to 50 seconds from fuel system pressurization from 1000 feet below sea level to 8000 feet altitude and following a 12-hour soak period in the ambient temperature range from -50° to 120°F (-45.6° to 48.9°C) provided:

- a. That the starting torque requirements shown on curve No. S-84, sheet 21 are met.
- b. That the fuel temperature requirements of 15.1 are met.
- c. That the fuel pressure requirements of 15.2 are met.
- d. That the electrical power requirements of 18.0 for starting are met.
- e. The engine inlet air total pressure divided by ambient pressure is not less than 0.99.
- f. That the oil temperature requirements of 14.3 are met.

20.2.1 Unsatisfactory Start - After an unsatisfactory start the engine must be cleared of residual fuel by motoring the engine for a period of 30 seconds with fuel and ignition off. The restart can be attempted immediately after clearing the engine.

21.0 SHUTDOWN - Normal engine shutdown shall be accomplished by placing the power lever in the idle position and placing the shutoff lever in the "Fuel Off" position. Emergency engine shutdown shall be accomplished by placing the shutoff lever in the "Fuel Off" position with the power lever in any position. Shutdown of the duct heater shall be accomplished by placing the power lever in any position other than in the thrust augmentation range.

22.0 WINDMILL OPERATION

22.1 Windmilling Performance - Estimated steady-state windmilling engine performance is defined by curve No. S-84, sheets 7 through 20 and the following equation:

$$F_{nr} = F_{gr} - (1 + W_{sc}) F_r$$

where:

- F_{nr} = net thrust including reverser-suppressor effects
- F_{gr} = gross thrust obtained from curve No. S-84, sheets 13 or 14 and δ_{t2} .
- W_{sc}^* = ratio of secondary airflow to engine airflow
- F_r = ram drag of engine airflow
- δ_{t2} = compressor inlet face average total pressure in psia divided by 14.7 psia.

*Temperature corrected secondary flow ratio is the same as physical secondary flow ratio during steady-state windmilling conditions since engine gas stream temperature is equal to secondary air temperature.

Pratt & Whitney Aircraft
Specification No. 2710

Necessary corrections must be applied during the performance calculation procedure to reflect the effects of customer air bleed and/or power extraction. The reverser-suppressor secondary flow ratio shall be determined from known characteristics of the nacelle secondary system to obtain the net windmilling thrust. Upon completion of a calculation where customer power extraction is specified, the validity of the calculation must be checked by determining if the customer power extraction specified plus the engine accessory load and high rotor friction power is within the limits indicated by curve No. S-84, sheet 17. This check may become iterative and affect earlier calculations. Should this result, the customer power extraction must be reduced and the calculation repeated until the limits shown on curve No. S-84, sheet 17 are observed.

23.0 REVERSE THRUST - The engine shall be capable of maximum reverse thrust operation within the envelope shown on curve No. S-84, sheet 32. The uninstalled estimated maximum reverse thrust is shown on curve No. S-84, sheet 33 for standard day operation and on curve No. S-84, sheet 34 for hot day operation when reingestion of exhaust gas is not experienced. This thrust is also based on a reverse effective flow area and a mean gas discharge angle with the exhaust nozzle centerline as specified in 6.1. The reverser is capable of maximum reverse operation within the reverser operating envelope for the time period specified in 6.1.1. However, continuous reverser operation at idle on the ground is allowable.

24.0 ENGINE NOISE LEVELS - The noise levels generated by the engine aft of the exhaust plane shall not exceed the values in table V along a line parallel to and 300 feet from the engine axis. Measurements may be made either on the line or on an arc of 300 feet radius and corrected to the line by the procedures prescribed in 2.2.6.

Table V. Engine Noise Levels

Net Thrust, lb	Noise Level, PNdb, Maximum
Maximum Augmented	139
23,900	122
12,000	107

The noise levels generated by the engine forward of the inlet flange plane shall not exceed the values in table VI along a line parallel to and 300 feet from the engine axis. Measurements may be made either on the line or on an arc of 300 feet radius and corrected to the line by the procedures prescribed in 2.2.6.

Table VI. Engine Noise Levels

Net Thrust, lb	Noise Level, PNdb, Maximum
Maximum Augmented	126
23,900	118
12,000	113

Pratt & Whitney Aircraft
Specification No. 2710

In addition, sound measurements on a 300 feet sideline between the inlet flange and exhaust planes will be made and shall not exceed the higher of the maximum values defined above. These noise levels shall be obtained during operation under the following conditions:

- a. Static operation on an outdoor test stand.
- b. P&WA bellmouth inlet.
- c. Production engine or an acoustically similar engine.
- d. Axis of reverser-suppressor parallel to ground.

24.1 Sound Calculations - Measured octave band sound pressure levels will be converted to perceived noise values using the method prescribed in 2.2.4. All noise data will be normalized to 59°F (15°C) and 70% relative humidity using the method prescribed in 2.2.5. At least 6 test runs shall be made at each condition and the results averaged for demonstration purposes. If limitations during static test prevent the recording of noise at the conditions specified in 24.0, the measurements will be taken at a suitable point and corrected to the specified distances. Correction of measured sound pressure levels to desired distances will be performed using the method prescribed in 2.2.6.

25.0 INSTRUMENTATION - The following shall be provided with the engine with connection provisions as shown on the Installation Drawing:

- a. Turbine exit pressure probes and averaging manifold.
- b. Instrumentation for providing an electrical representation of average and individual probe exhaust gas temperature.
- c. Duct nozzle position indication.
- d. Reverser position indication.
- e. Aerodynamic brake indication.
- f. Ignition "On" indication.
- g. Low rotor speed indication (electrical counter type).
- h. Secondary airflow valve position indication.

25.1 Provisions - Provisions for the following instrumentation shall be as shown on the Installation Drawing:

- a. High rotor speed tachometer.
- b. Oil-in temperature.
- c. Oil pressure.
- d. Pressure drop across oil strainer.
- e. Oil level.
- f. Chip detectors (oil).
- g. Primary gas generator fuel flowmeter.
- h. Duct heater fuel flowmeter.
- i. Fuel pump inlet pressure.
- j. Fuel inlet temperature.
- k. Pressure drop across fuel filter.
- l. Vibration pickup mounting brackets (2).

25.2 Special Instrumentation Installation - Installation of all special engine instrumentation must be coordinated with and approved by P&WA.

26.0 TURBINE COOLING SYSTEM - The turbine cooling system is a self-contained, fixed orifice and self-regulating system which does not require an airframe supplied input.

26.1 Turbine Temperature Measurement System - The engine shall be equipped with thermocouples for use in conjunction with the airframe temperature indicating system. The thermocouples shall permit consistent measurement of exhaust gas temperature. The system design shall be such that it is possible to service check individual temperature probes for continuity.

27.0 CUSTOMER REQUIREMENTS

27.1 Drive Power Extraction - The maximum allowable continuous horsepower extraction and overload horsepower extraction at the power takeoff pad for all operating conditions as a function of high pressure compressor rotor speed is as specified in the form of torques and speed ratios on the Installation Drawing.

27.1.1 Dynamic Loading - The dynamic loading limit of the drive pad is specified on the Installation Drawing.

27.1.2 Power Takeoff Shaft Speed - Power takeoff shaft speed ratio is specified on the Installation Drawing.

27.1.3 Shear Section - The shear section requirements are specified on the Installation Drawing.

27.1.4 Mounting Pad and Power Takeoff (PTO) Shaft Loads - The mounting pad and PTO shaft load specifications are shown on the Installation Drawing.

27.1.5 Hydraulic Pump Drive Pads - Hydraulic pump pads shall be provided as shown on the Installation Drawing.

27.2 Compressor Bleed Air

27.2.1 Quality - The air at the engine bleed ports shall not contain quantities of engine generated noxious, toxic or irritating substances above the maximum threshold limit values of the substances shown below:

Substances	Parts per Million (Volume)
Carbon dioxide	5000.0
Carbon monoxide	50.0
Carbon tetrachloride	50.0
Decaborane	0.05
Diborane	0.1
Pentaborane	1000.0
Ethyl alcohol (ethanol)	0.1

Substances (continued)	Parts per Million (Volume)
Fluorine	0.1
Fuels, aviation	250.0
Hydrogen peroxide	1.0
Methyl alcohol (methanol)	200.0
Methyl bromide	20.0
Monochlorobromomethane	40.0
Nitrogen dioxide	5.0
Oil breakdown products (aldehydes, acrolein, etc.)	1.0
Ozone	0.1
Unsym-dimethyl hydrazine	0.5

The air shall contain a total of not more than 5 milligrams per cubic meter of submicron particles.

Dirt or other foreign particle concentration in the bleed air after expansion to atmospheric pressure shall not exceed that of the air at the engine inlet on a per unit volume basis. If a demonstration is required P&WA will demonstrate on a normally functioning engine on a P&WA plant test stand that the above requirements are met within the accuracy of the testing technique available to P&WA at the time of the demonstration. However, it must be recognized that there may be occasional instances in service operation when the bleed air is contaminated.

27.2.1.1 Seals and Oil Lines - Accessory seals, bearing seals, and oil lines shall be designed so that a single failure (except for engine bearing failure) can not result in bleed air contamination. P&WA shall submit a failure analysis to the airframe manufacturer to demonstrate how the design meets this requirement.

27.2.2 Quantity - The engine shall provide for high pressure compressor air extraction, for aircraft use, as indicated:

- a. Within the operating envelope of the engine, high compressor air will be available in quantities not to exceed 5% of gas generator airflow from idle to a thrust corresponding to a turbine exhaust gas temperature 80°F (44.4°C) less than that corresponding to maximum cruise.
- b. Within the operating envelope of the engine, high compressor air will be available in quantities not to exceed 3% of gas generator airflow from a thrust corresponding to a turbine exhaust gas temperature 80°F (44.4°C) less than that corresponding to maximum cruise, to takeoff thrust.

The number, location and connection flange details of the bleed ports are defined on the Installation Drawing. Changes of compressor air extraction must not exceed 1% per second. For high pressure compressor air extraction, within the limits specified, the pressure and temperature at the engine bleed ports shall be as provided by curve No. S-84, sheet 1. The effects upon engine performance when bleeding air from the engine shall be as provided by curve No. S-84, sheet 1.

28.0 ENGINE TYPE CERTIFICATION TEST - P&WA will conduct engine tests as necessary to satisfy the engine Type Certificate requirements of 2.1.4.

29.0 ACCEPTANCE TEST - An acceptance test shall be conducted on each production engine in accordance with then current P&WA Test Instruction Sheets and shall consist only of the specified test. Copies of the acceptance test log sheets shall be retained by P&WA for each engine for a period of 2 years. Thrust, airflow, rpm, fuel flow rate, specific fuel consumption, gas pressures, and gas temperatures shall be corrected in accordance with P&WA standard analytical and correction procedures.

29.1 Accuracy - For all engine and component calibrations and tests, reported data shall have a steady-state accuracy within P&WA normal tolerances. All instruments and equipment shall be calibrated as necessary to insure that the degree of accuracy required by this specification is realized.

29.2 Fuel and Oil - Fuel and oil used for all testing shall be as specified in 2.2.1 and 2.2.2, respectively.

30.0 QUALITY ASSURANCE PROVISIONS

30.1 Quality Evidence Tests - Evidence of suitable quality of materials, parts, and components shall be based on physical inspection and process control data and may be supplemented by physical and chemical tests to determine the extent of conformance of the quality characteristics to P&WA specifications and drawings.

30.1.1 Magnetic Inspection - The following parts, if made of magnetic materials, shall be subject to magnetic particle inspection in accordance with P&WA established procedures:

- a. All parts constituting the compressor-turbine rotor assembly, including threaded fastenings.
- b. Other highly stressed parts, except that fluorescent penetrant or radiographic inspection may be substituted when this method is more readily applied to the part and provides adequate means for detecting detrimental defects, or when interpretation of indications can be more positively controlled.
- c. All accessory drive and vibration or friction dampener springs.
- d. Starter jaw.
- e. All gears.
- f. All quill and accessory drive shafts.

30.1.2 Fluorescent Penetrant Inspection - The following parts, if made of nonmagnetic materials, shall be subject to fluorescent penetrant inspection in accordance with P&WA established procedures:

- a. All parts of the compressor-turbine rotor assembly, including threaded fastenings except those parts on which anodic inspection is used.
- b. Turbine nozzle vanes and assemblies.
- c. All other highly stressed parts.

Very bulky and intricately shaped parts may be hydrostatically tested by the P&WA approved method in lieu of fluorescent testing. Radiographic inspection may be substituted for fluorescent penetrant inspection of fusion welds.

30.1.3 Excepted Parts - Low stressed parts, such as cotter pins, washers, etc., are not required to be inspected by the magnetic or fluorescent methods.

30.1.4 Radiographic or Ultrasonic Inspection - The following shall be subject to radiographic or ultrasonic inspection:

- a. The compressor rotors, if nonmagnetic.
- b. The turbine rotors, if nonmagnetic.
- c. Highly stressed nonmagnetic castings.

30.1.4.1 Radiographic Inspection - Radiographic inspection of materials shall be in accordance with the P&WA established procedures. Laboratories performing radiographic inspection shall be certified in accordance with P&WA requirements.

30.1.5 Certification of Operators - All fusion welding shall be performed by operators who are certified in accordance with P&WA established procedures.

31.0 PREPARATION FOR DELIVERY

31.1 Preparation for Storage and Shipment - The engine, components, and accessories shall be prepared for storage and shipment in accordance with P&WA established procedures. P&WA shall furnish a packing list with each engine. All parts, accessories, components, and tools which are not installed on the engine, but which are shipped with the engine, shall be included on the packing list. P&WA shall furnish with each engine the Acceptance Run Log with all performance data.

Figure 2

JTF 17A-21B TURBOFAN ENGINE
AERODYNAMIC LOADS ON ENGINE POD

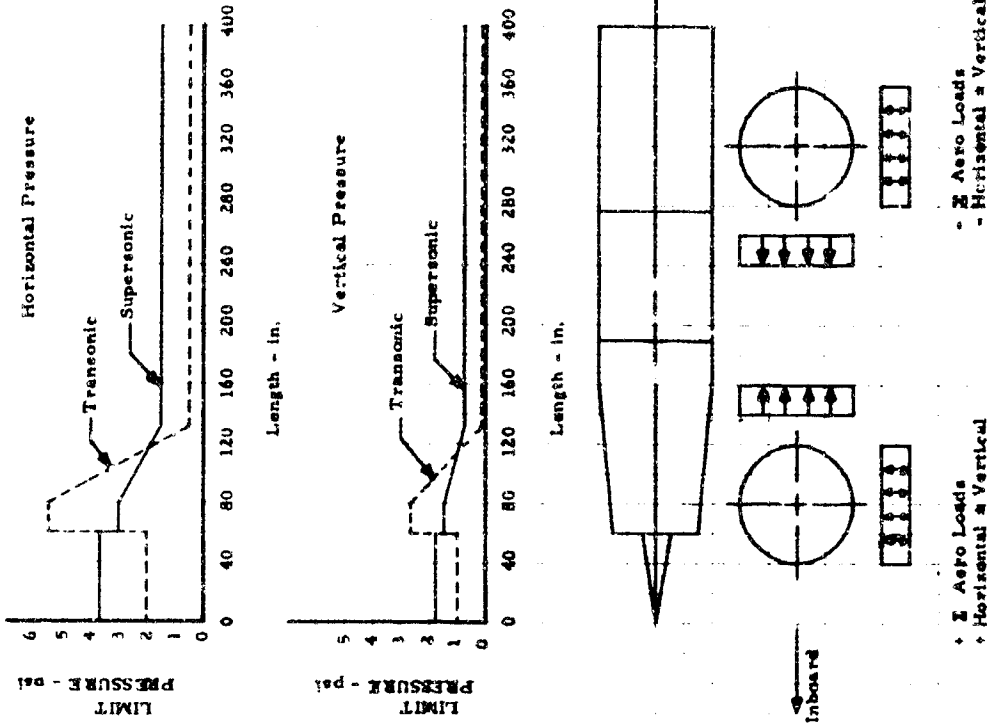

8-A-66

Figure 1

JTF 17A-21B TURBOFAN ENGINE
MANEUVER LOAD DIAGRAM

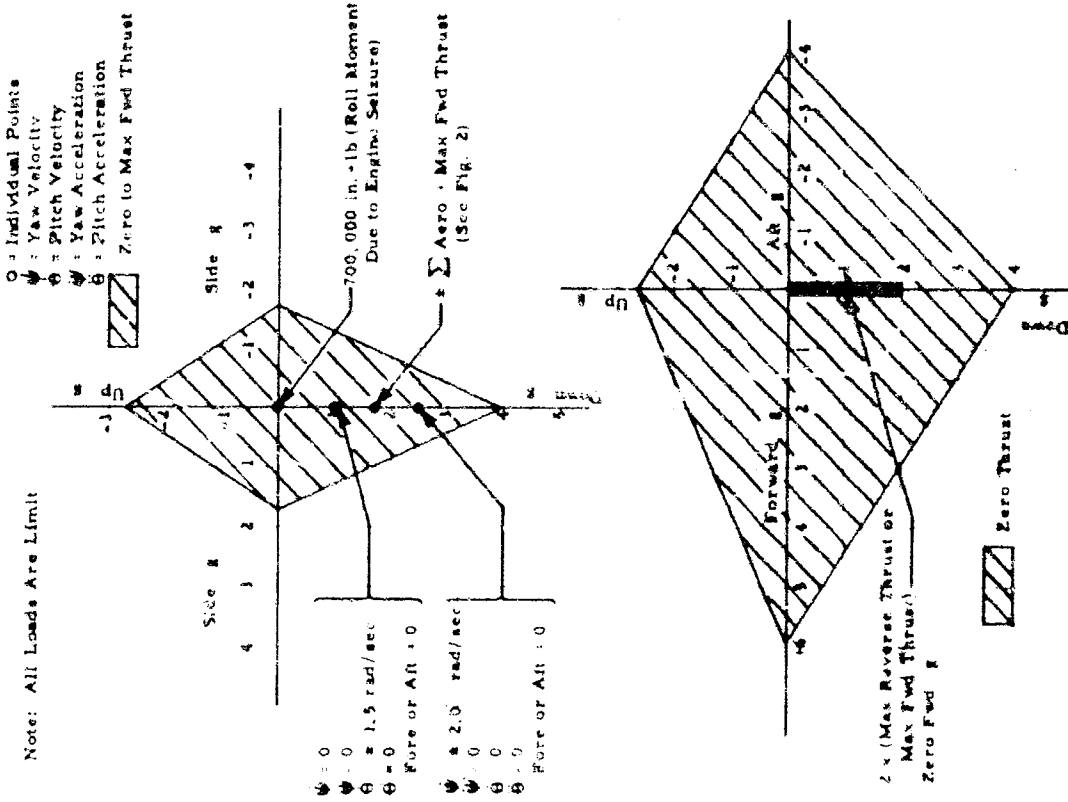

8-A-66

Pratt & Whitney Aircraft
Specification No. 2710

Curve No. S-84

JTF17A-21B TURBOFAN ENGINE
ESTIMATED ENGINE OPERATING ENVELOPE

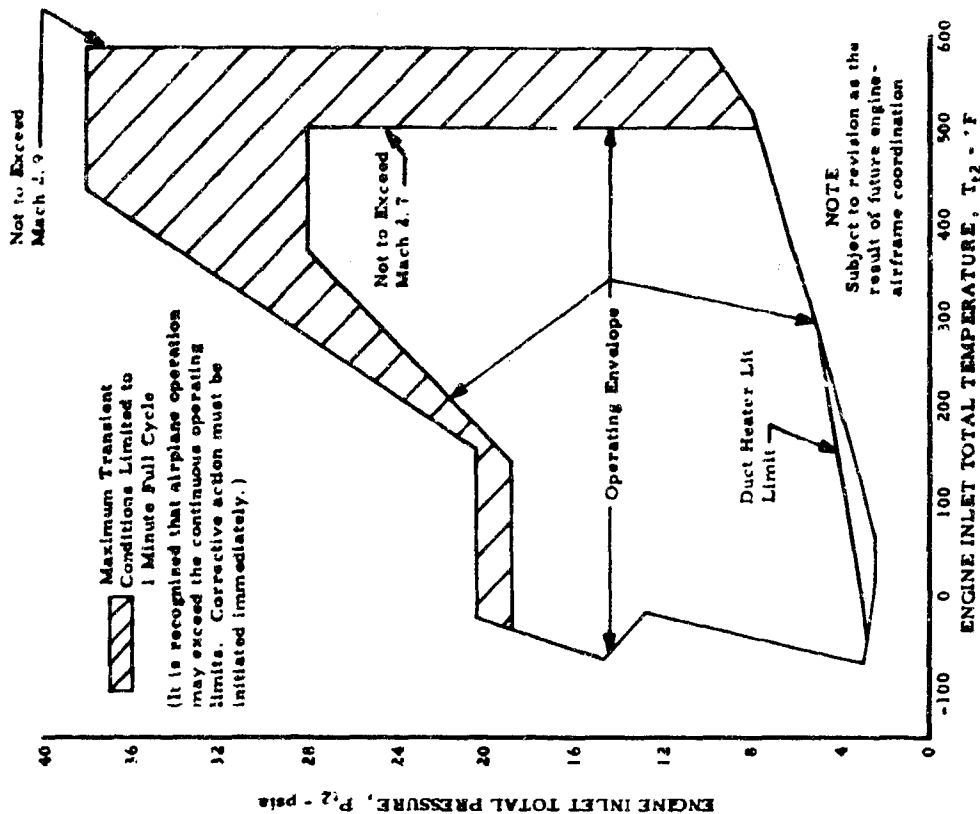

Maximum Transient Conditions Limited to 1 Minute Full Cycle
 (It is recognized that airplane operation may exceed the continuous operating limits. Corrective action must be initiated immediately.)

NOTE
 Subject to revision as the result of future engine-airframe coordination

ENGINE INLET TOTAL PRESSURE, P_{t2} - psia

ENGINE INLET TOTAL TEMPERATURE, T_{t2} - °F

DF 46162 R-1

1-8-66

Sheet 2

Estimated JTF17A-21B Turbofan Engine Performance

PWA Deck No. 5573 Date: 8-8-66

Sheet 1

JTF17A-21B TURBOFAN ENGINE
ESTIMATED WINDMILLING RESTART ENVELOPE
WITHOUT AERODYNAMIC BRAKING

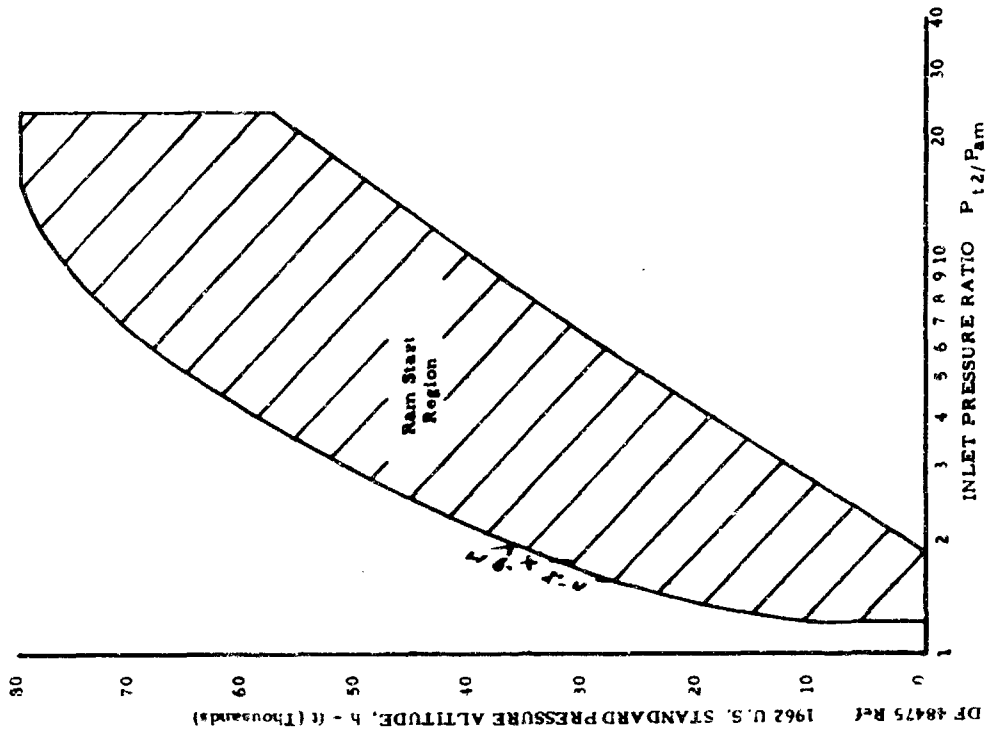

JTF17A-21B TURBOFAN ENGINE
ESTIMATED ENGINE OPERATING ENVELOPE
1962 U.S. STANDARD ATMOSPHERE (GEOMETRIC)
INLET PRESSURE RECOVERY PER SHEET 3

NOTE

- 1) Based on P_{t2} and T_{t2} limits per sheet 2 with specific heat ratio, C_p/C_v , constant 1.4
- 2) Subject to revision as the result of future engine-airframe coordination

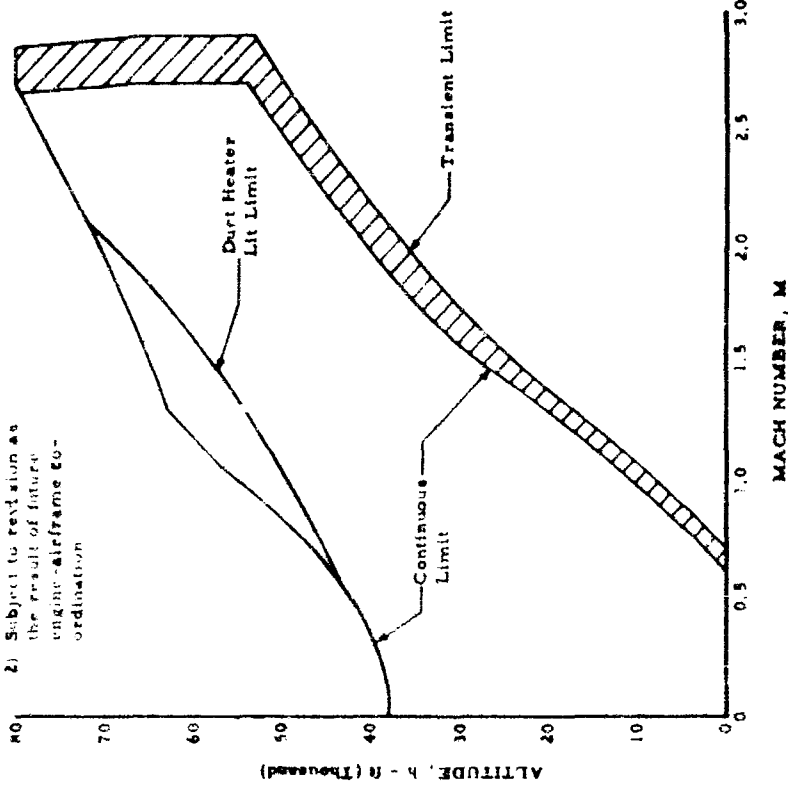

Pratt & Whitney Aircraft
Specification No. 2710

Curve No. S-84

JTF17A-21B TURBOFAN ENGINE
ESTIMATED CORRECTED AIRFLOW SCHEDULE
AT MAXIMUM NONAUGMENTED THROUGH MAXIMUM AUGMENTED POWER
1962 U. S. STANDARD ATMOSPHERE (GEOMETRIC)

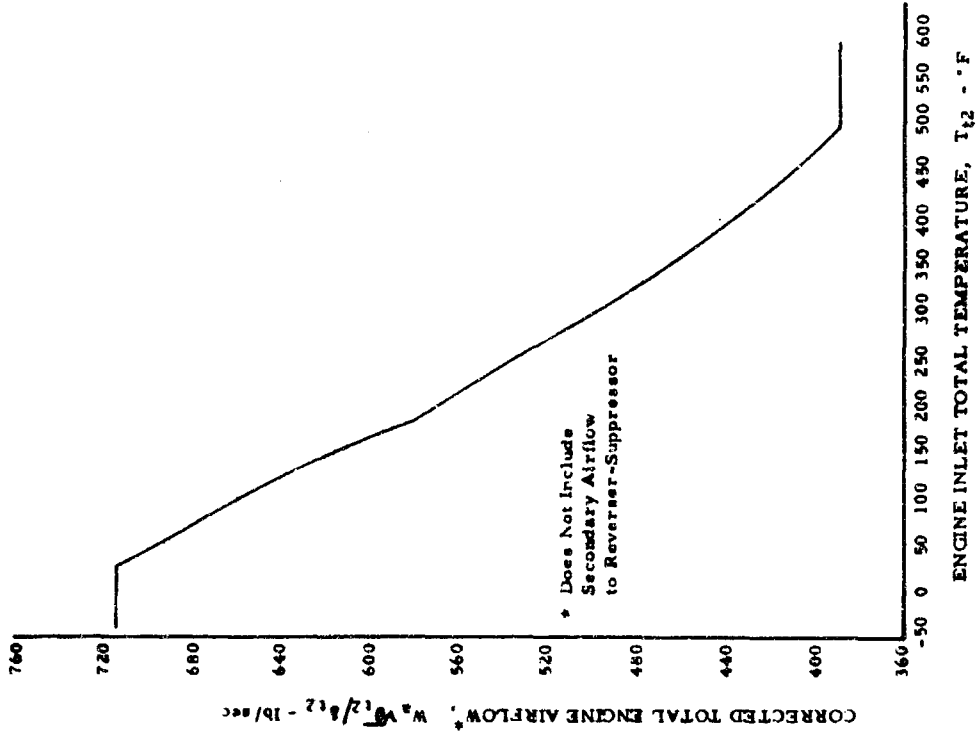

DF 48531 R-4

Sheet 6

Curve No. S-84

JTF17A-21B TURBOFAN ENGINE
ESTIMATED INLET TOTAL PRESSURE RECOVERY P_{t_2}/P_{t2p}
PER (MIL-E-5008B)

Below Mach 1 - 1.0
 Above Mach 1 - 1.0 - 0.075 (M-1.0) 1.35
 P_{t_2} = Compressor Inlet Total Pressure
 P_{t2p} = Isentropic Compressor Inlet Total Pressure

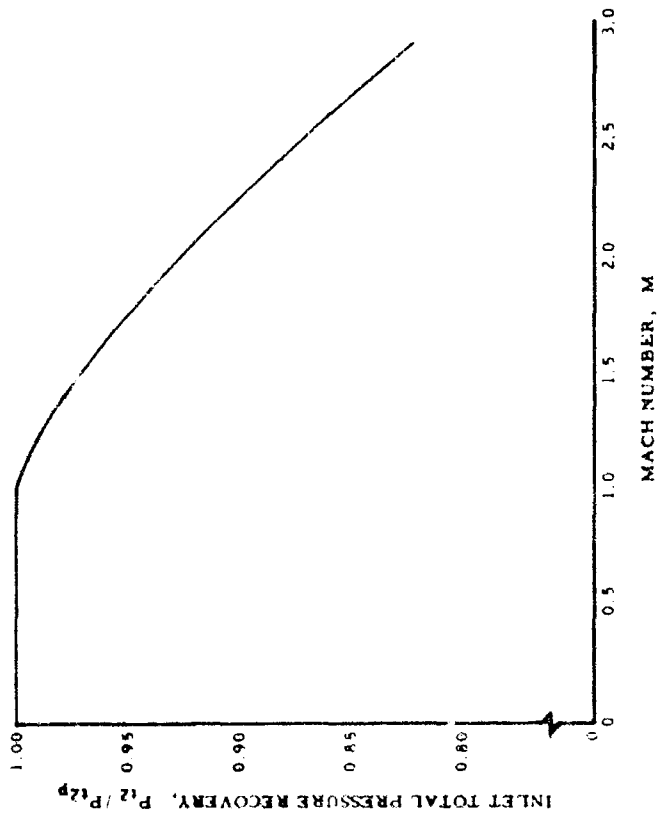

DF 48531 R-4

Sheet 5

Curve No. S-84

JTF17A-21B TURBOFAN ENGINE
ESTIMATED WINDMILLING PERFORMANCE
WITH AERODYNAMIC BRAKING

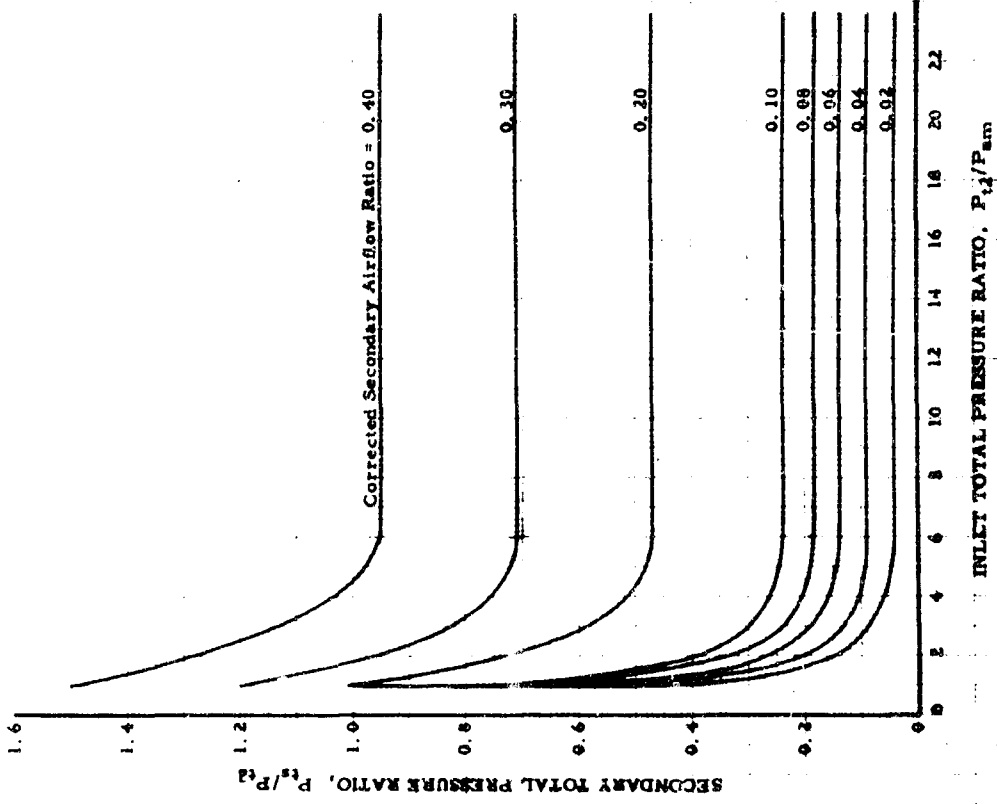

DF 47590 Rev

8-8-66

Sheet 7

Curve No. S-84

JTF17A-21B TURBOFAN ENGINE
ESTIMATED WINDMILLING PERFORMANCE
WITHOUT AERODYNAMIC BRAKING

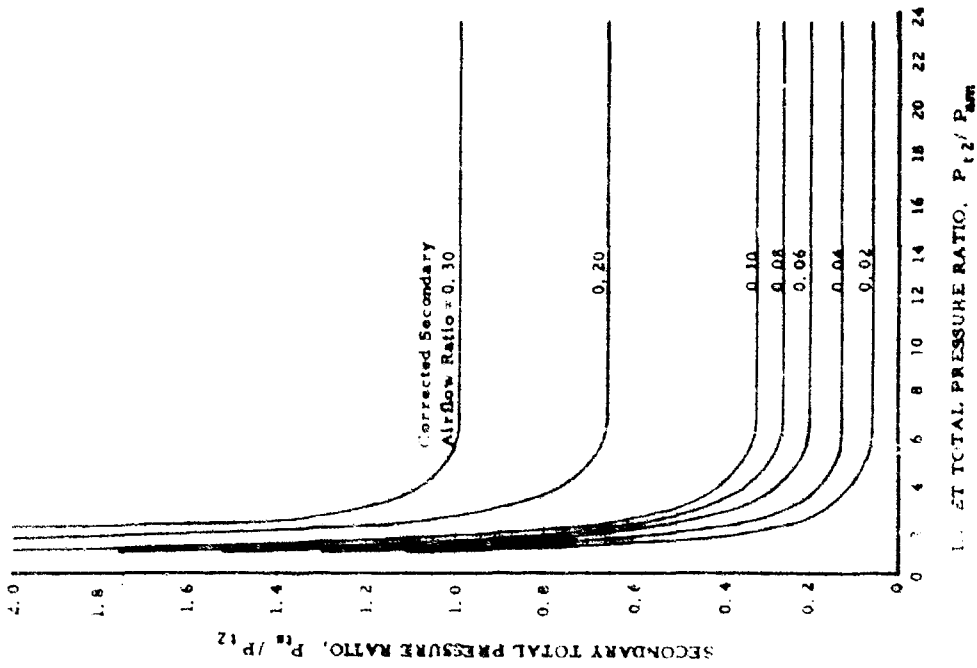

DF 47990 Rev

Sheet 8

Pratt & Whitney Aircraft
Specification No. 2710

Curve No. S-84

JTF17A-21B TURBOFAN ENGINE
 ESTIMATED CORRECTED LOW ROTOR SPEED
 WINDMILLING

NOTE
 Design corrected low rotor speed
 $N_1 \sqrt{P_{t2}} = 6490 \text{ rpm}$

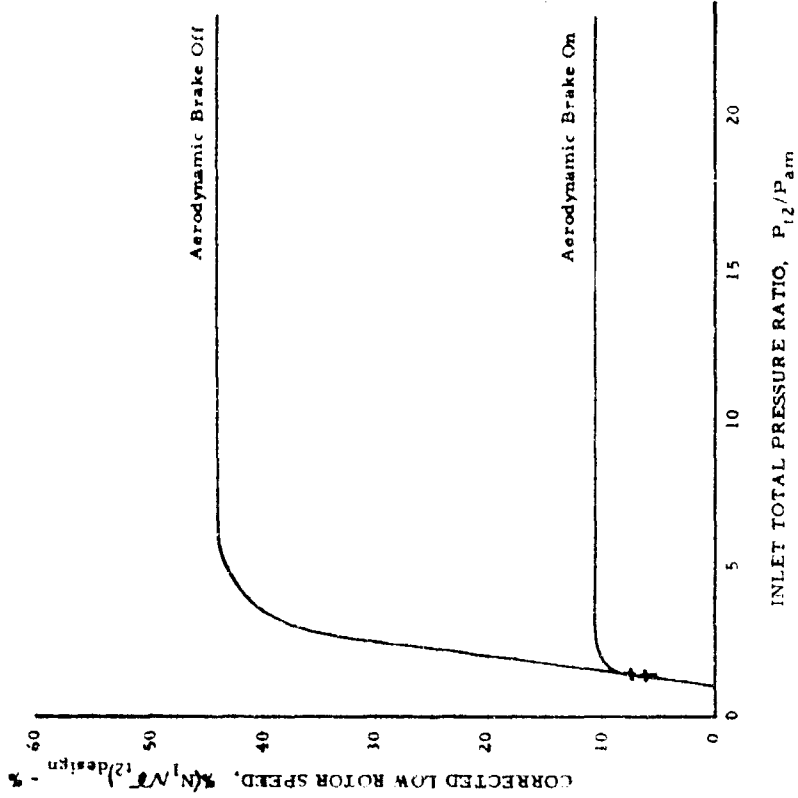

Sheet 10

Curve No. S-84

JTF17A-21B TURBOFAN ENGINE
 ESTIMATED CORRECTED TOTAL ENGINE AIRFLOW
 WINDMILLING

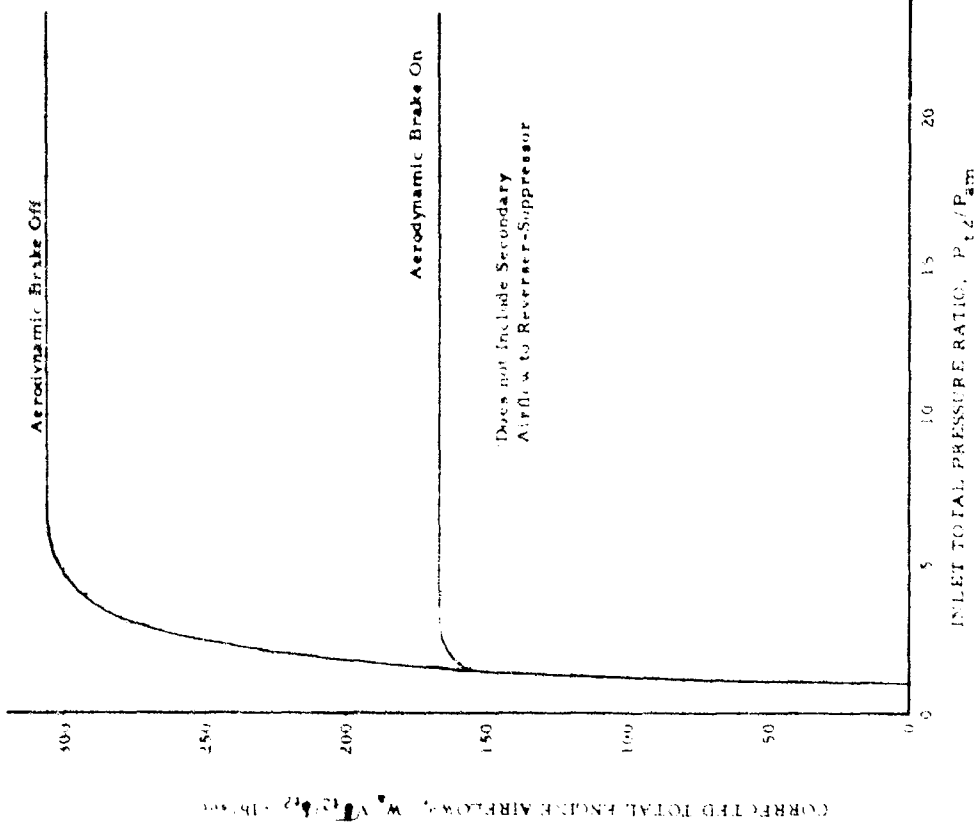

Sheet 9

5-8-66

JTF17A-21B TURBOFAN ENGINE
ESTIMATED WINDMILLING PERFORMANCE
WITHOUT AERODYNAMIC BRAKING

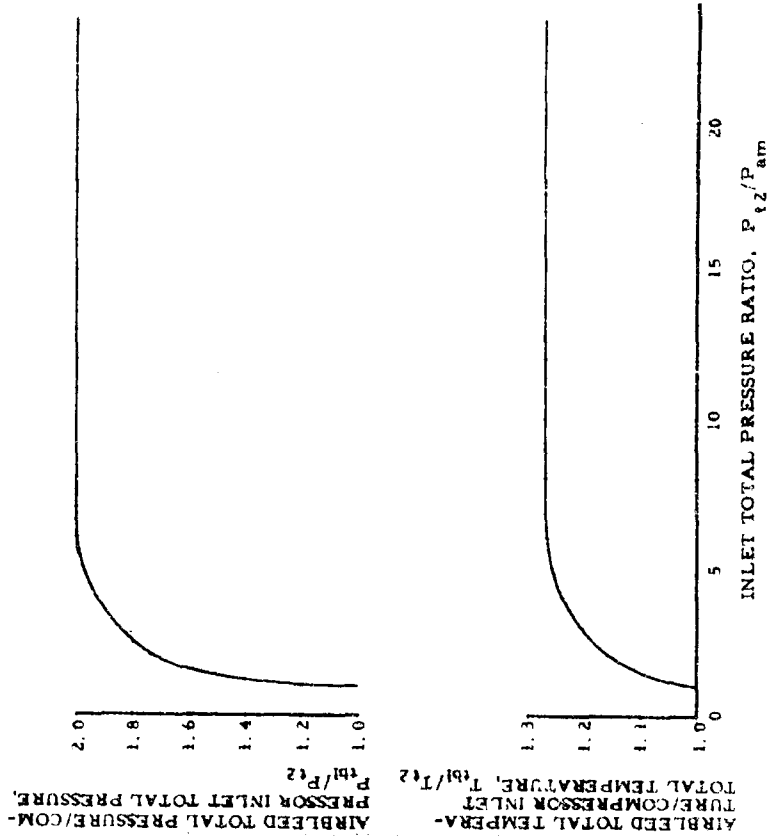

Sheet 12

JTF17A-21B TURBOFAN ENGINE
ESTIMATED CORRECTED HIGH ROTOR SPEED
WINDMILLING

NOTE

Design corrected high rotor speed
 $N_2/\sqrt{T_{t2}} = 6190$ rpm

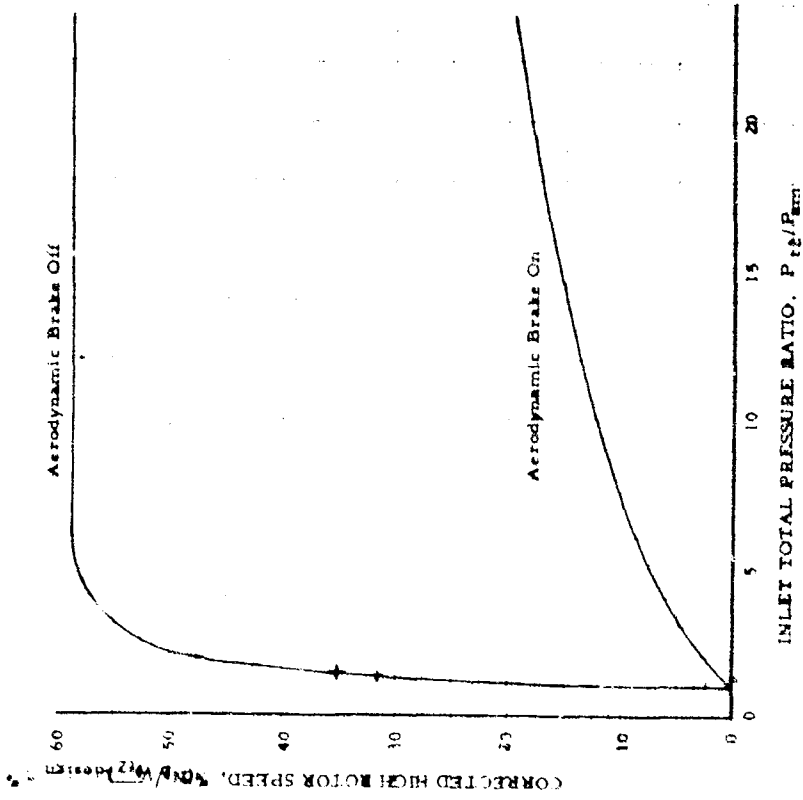

Sheet 11

Pratt & Whitney Aircraft
Specification No. 2710

Curve No. S-84

JTF17A-21B TURBOFAN ENGINE
ESTIMATED CORRECTED GROSS THRUST WHILE
WINDMILLING WITH AERODYNAMIC BRAKING

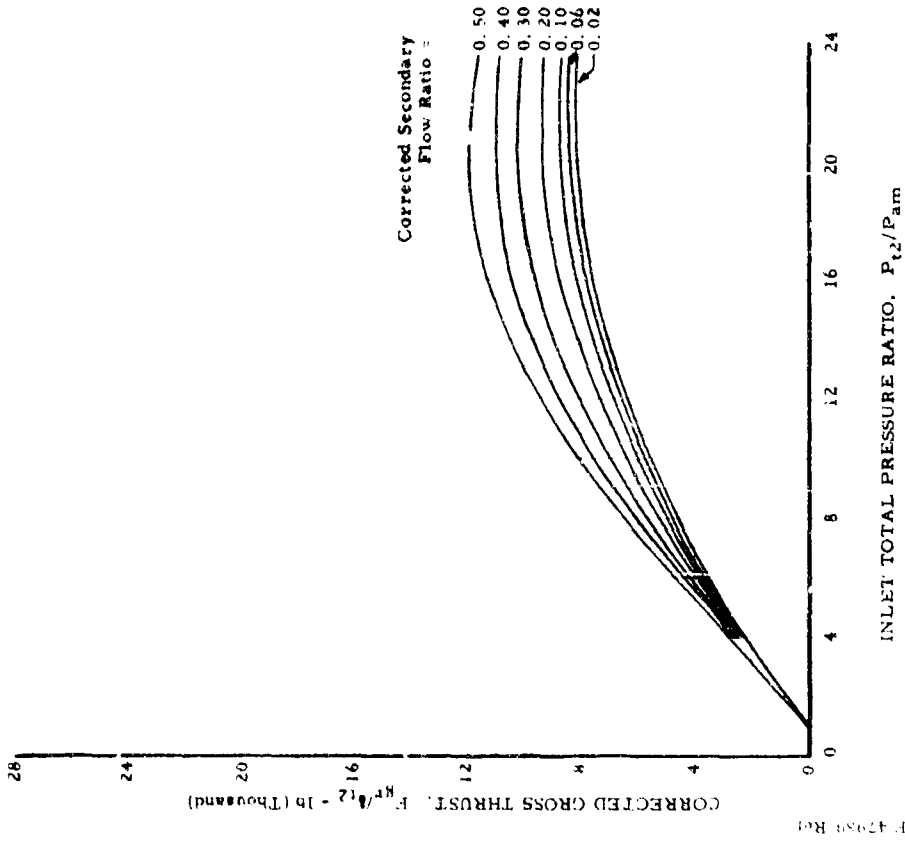

Sheet 14

Curve No. S-84

JTF17A-21B TURBOFAN ENGINE
ESTIMATED CORRECTED GROSS THRUST WHILE
WINDMILLING WITHOUT AERODYNAMIC BRAKING

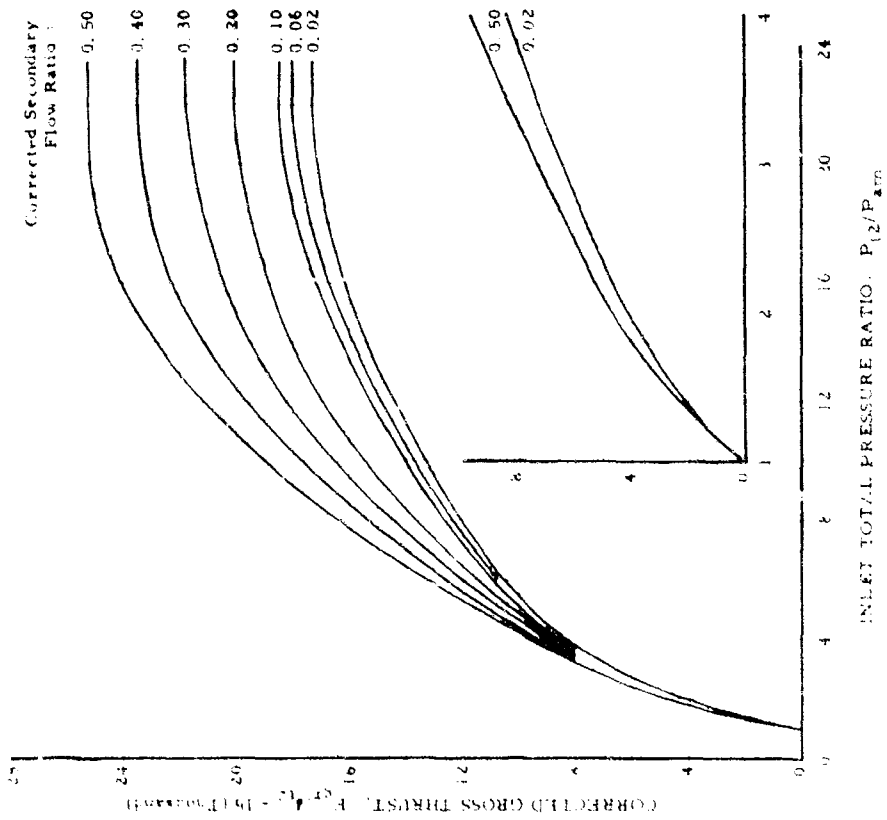

Sheet 13

JTF17A-21B TURBOFAN ENGINE.
ESTIMATED VARIATION OF WINDMILLING
PERFORMANCE WITH HIGH PRESSURE
COMPRESSOR AIRBLEED

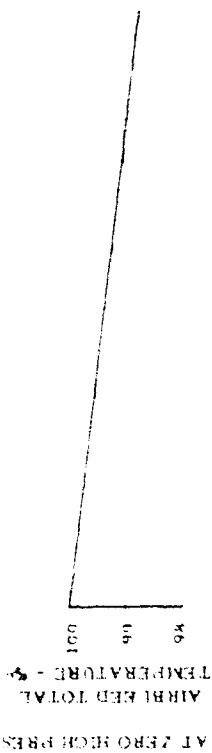
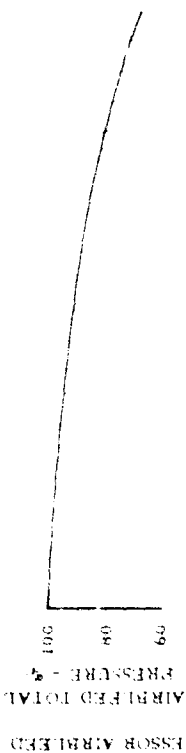

NOTE
Bypass ratio and high rotor
speed remain constant with
high pressure compressor
airbleed

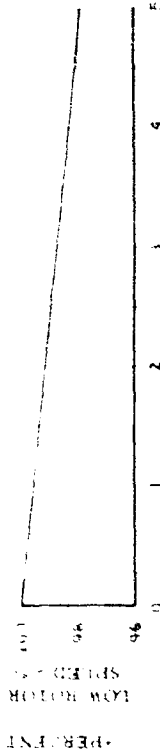

HIGH PRESSURE COMPRESSOR AIRBLEED, W_{H1}/W_{2c} - %

JTF17A-21B TURBOFAN ENGINE.
ESTIMATED VARIATION OF WINDMILLING
PERFORMANCE WITH HIGH PRESSURE
COMPRESSOR AIRBLEED

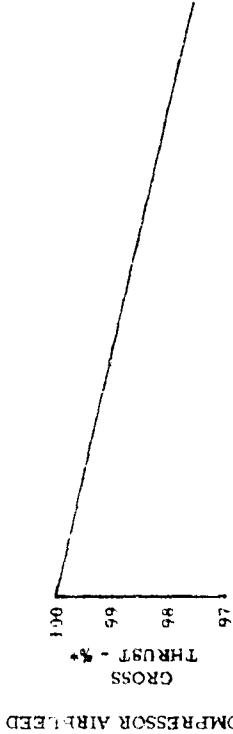

NOTE
Does not include secondary
flow to reverser-suppressor.

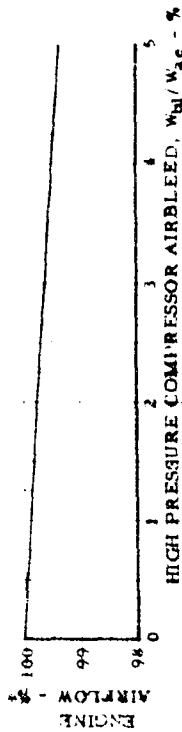

Curve No. 554

JTF17A-21B TURBOFAN ENGINE
ESTIMATED POWER REQUIRED TO OVERCOME
ENGINE ACCESSORY LOADS AND HIGH AC TOR FRICTION
WHILE WINN MELLING

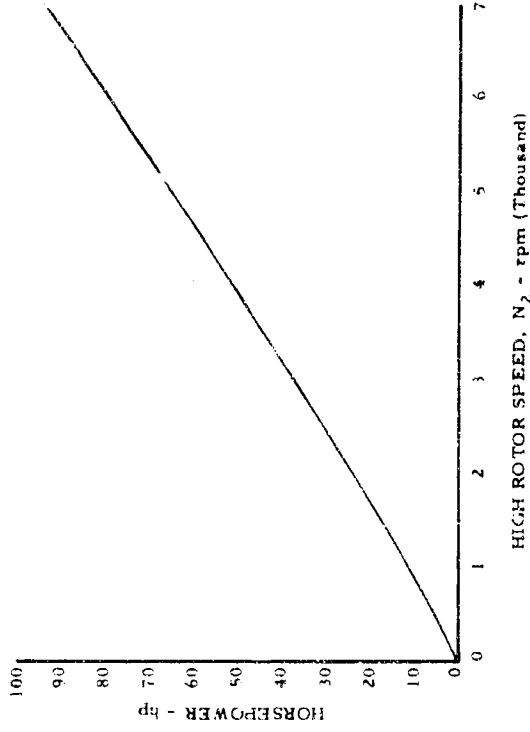

DF 4794 R01

Sheet 14

Curve No. 554

JTF17A-21B TURBOFAN ENGINE
ESTIMATED POWER AVAILABLE FROM
HIGH PRESSURE ROTOR WITH ENGINE
WINDMILLING AND NO AERODYNAMIC BRAKING

Inlet Total Pressure Ratio, P_{t2}/P_{am}

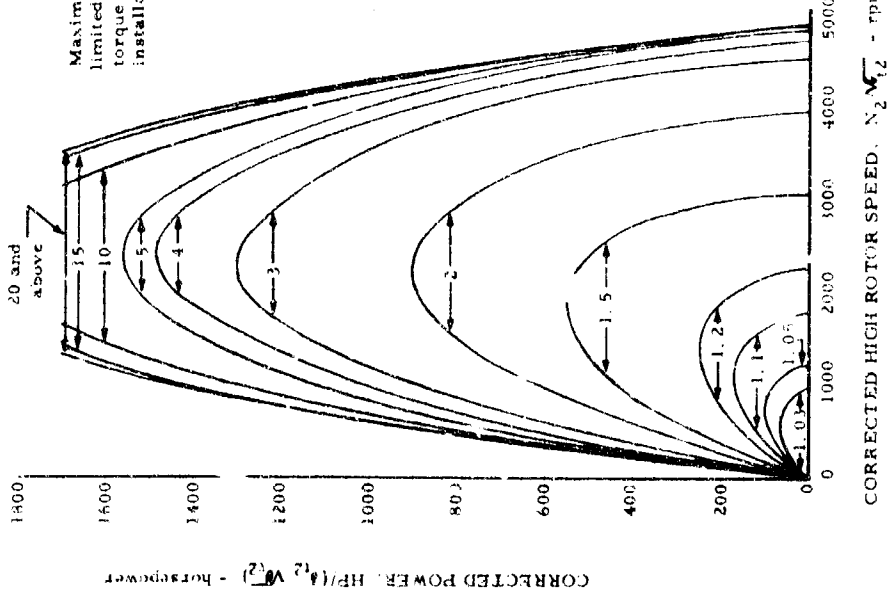

DF 4798 R01

Sheet 15

Curve No. S-84

JTF17A-21B TURBOFAN ENGINE
ESTIMATED VARIATION OF WINDMILLING
PERFORMANCE WITH POWER EXTRACTIONS

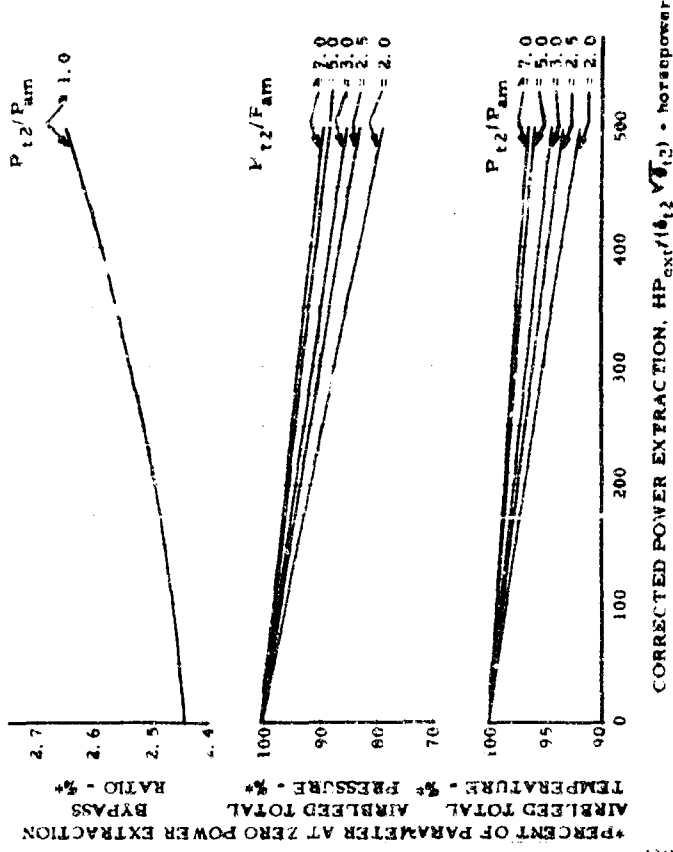

DF 4798 R1

Sheet 20

8-8-66

Curve No. S-84

JTF17A-21B TURBOFAN ENGINE
ESTIMATED VARIATION OF WINDMILLING
PERFORMANCE WITH POWER EXTRACTIONS

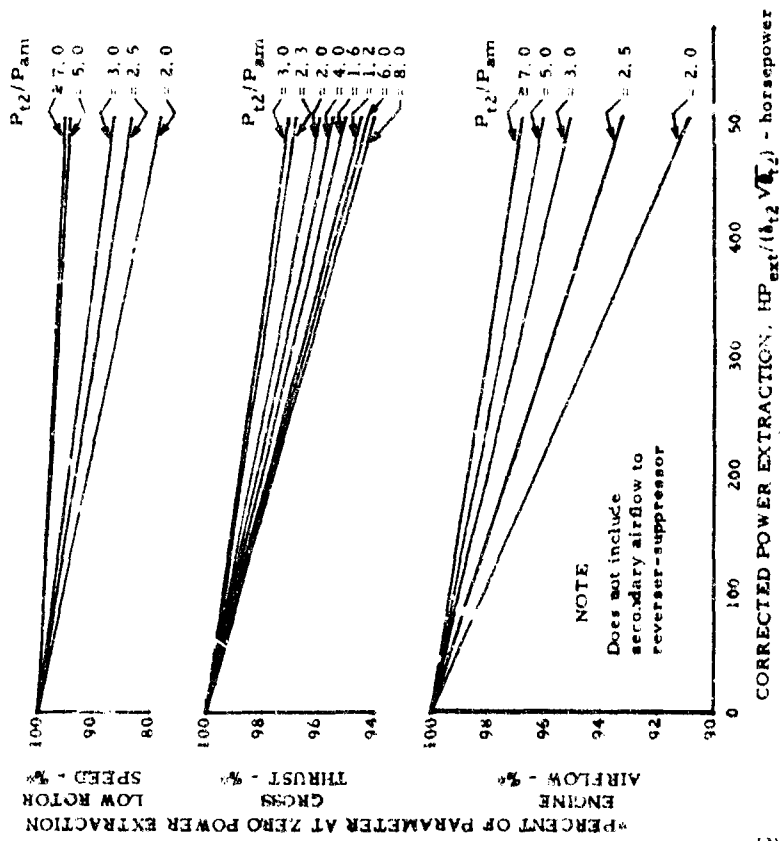

DF 4798 R1

Sheet 19

8-8-66

Curve No. S-54

TF17A-21B TURBOFAN ENGINE
ESTIMATED STARTING REQUIREMENTS
ZERO POWER EXTRACTION
INLET PRESSURE RECOVERY PER SHEET 5
SEA LEVEL STATIC

NOTE

- (1) Gear ratio = 0.977
(PTO speed = 0.977 N₂ engine speed)
- (2) Equivalent mass polar moment of inertia at PTO pad = 22.5 slug ft²

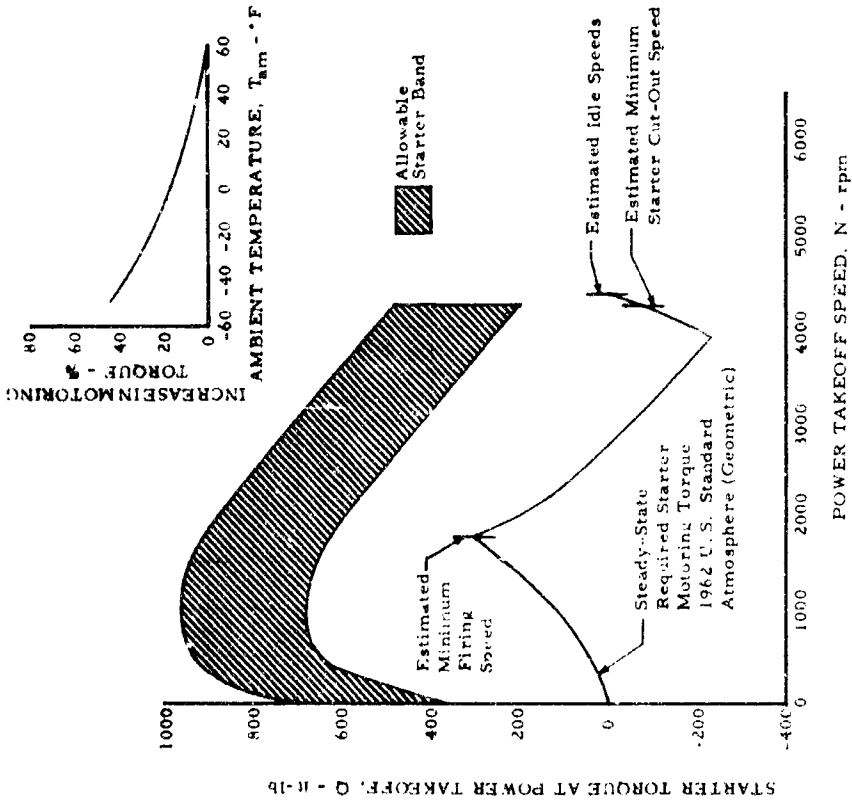

Curve No. S-54

TF17A-21B TURBOFAN ENGINE
ESTIMATED ENGINE ACCELERATION TIME FROM IDLE TO MAXIMUM THRUST
1962 U.S. STANDARD ATMOSPHERE (GEOMETRIC)
INLET PRESSURE RECOVERY PER SHEET 5
SEA LEVEL STATIC

Design High Rotor Speed, N₂ design = 8190 rpm

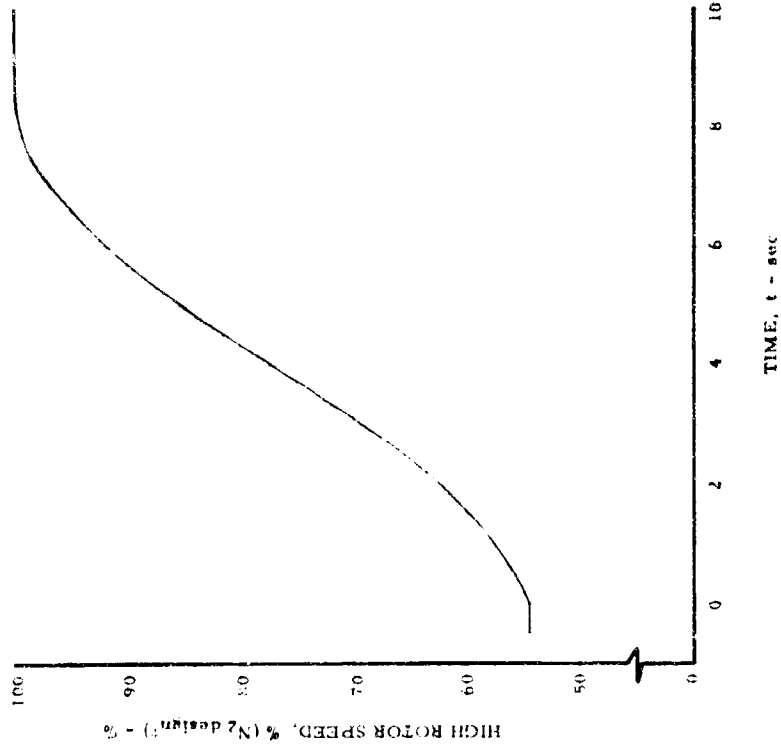

DE 4765 ROT

Sheet 21

Sheet 22

Curve No. S-84

JTF17A-21B TURBOFAN ENGINE
ALLOWABLE TIME AT MAXIMUM FUEL TEMPERATURE LIMIT

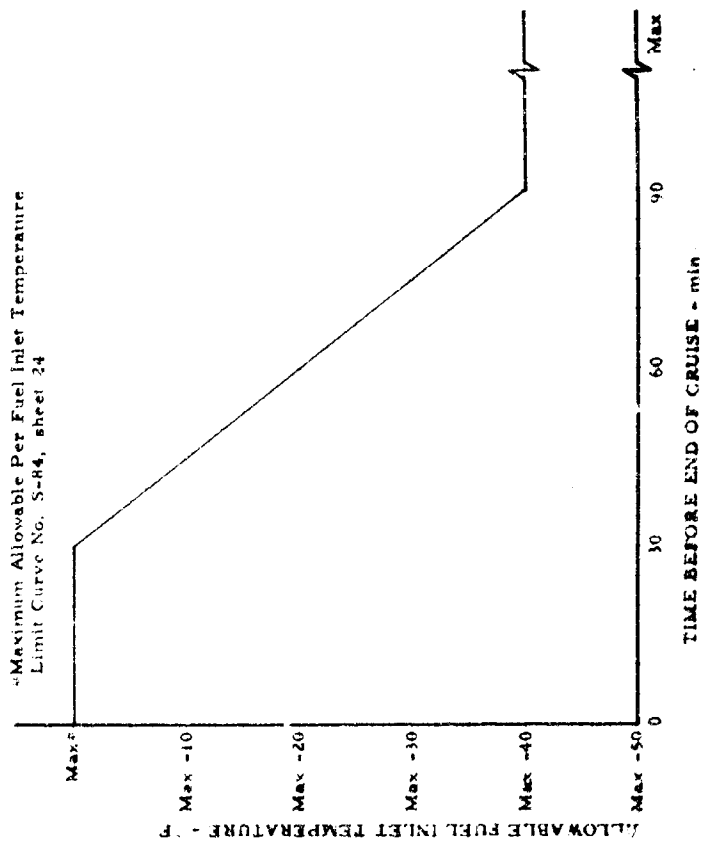

S-X-66

Sheet 23

X-H-66

Curve No. S-85

JTF17A-21B TURBOFAN ENGINE
FUEL INLET TEMPERATURE LIMITS
ALLOWABLE UP TO 30 MINUTES BEFORE END OF CRUISE
REFER TO SHEET 23 FOR LIMITS OVER 30 MINUTES
PWA 522 (JET A, A-1)
NO HEAT RETURN TO AIRFRAME

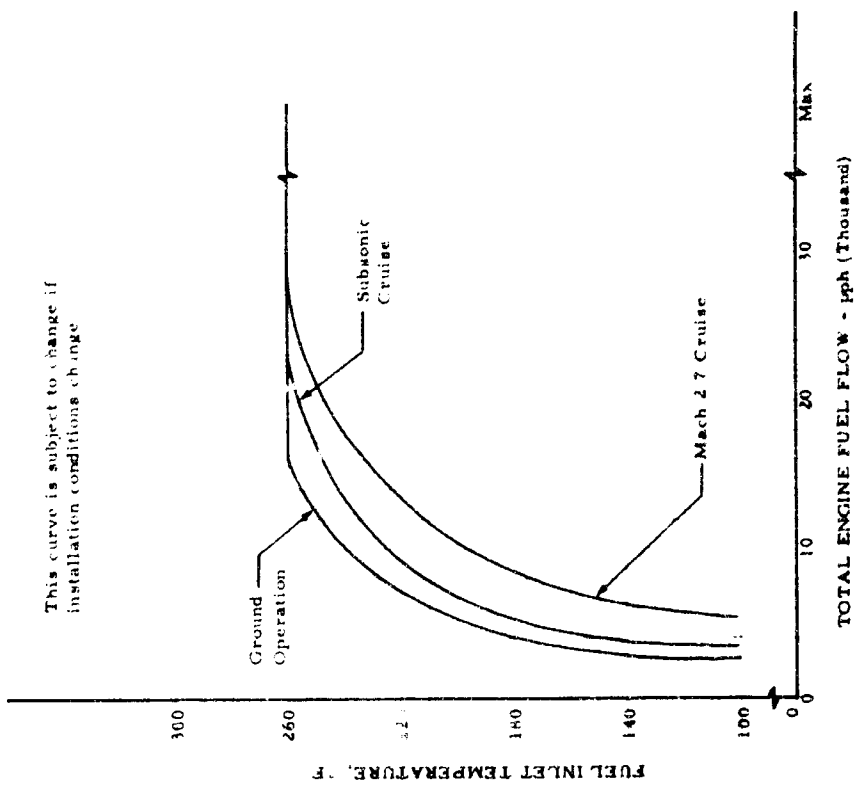

Sheet 22

Curve No. 5-04

JTF17A-41B TURBOFAN ENGINE
ESTIMATED ALLOWABLE FUEL PRESSURE FLUCTUATION
AT ENGINE FUEL INLET CONNECTION

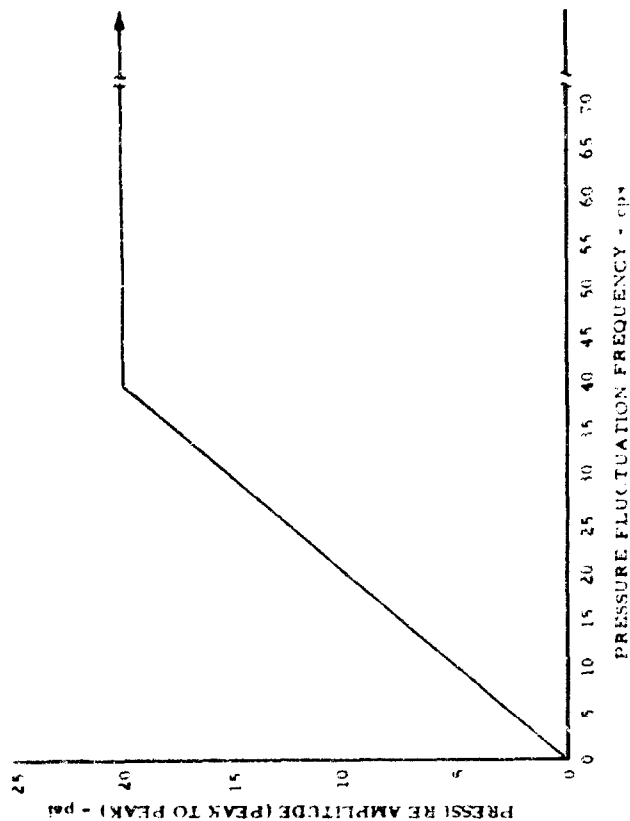

Sheet 25

Curve No. 5-04

JTF17A-41B TURBOFAN ENGINE
ESTIMATED POWER LEVER OPERATION
(FUNCTIONAL REPRESENTATION)

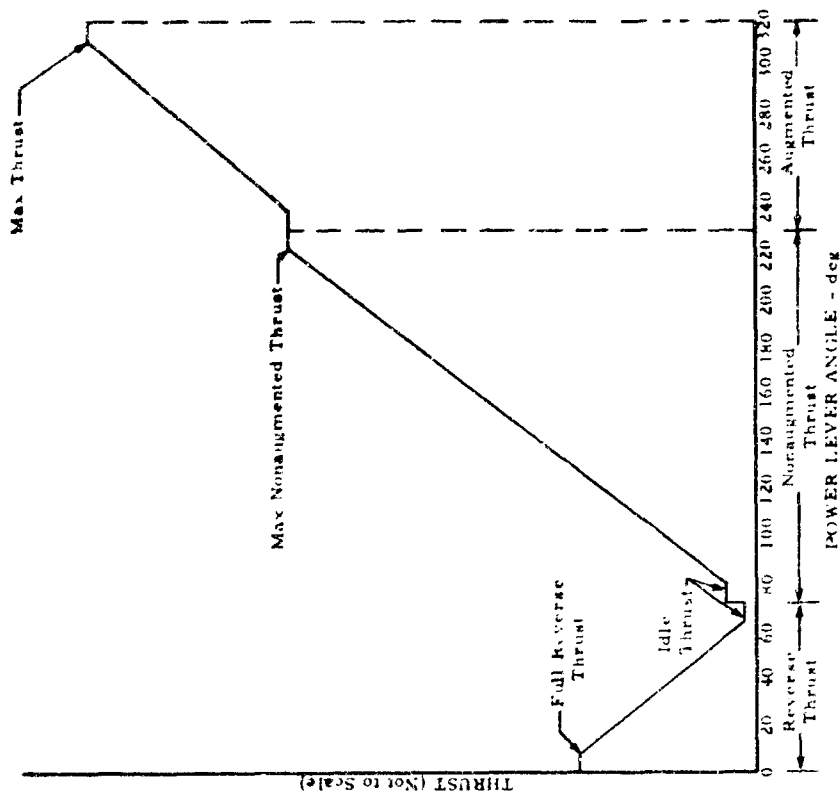

Sheet 26

Pratt & Whitney Aircraft
Specification No. 2710

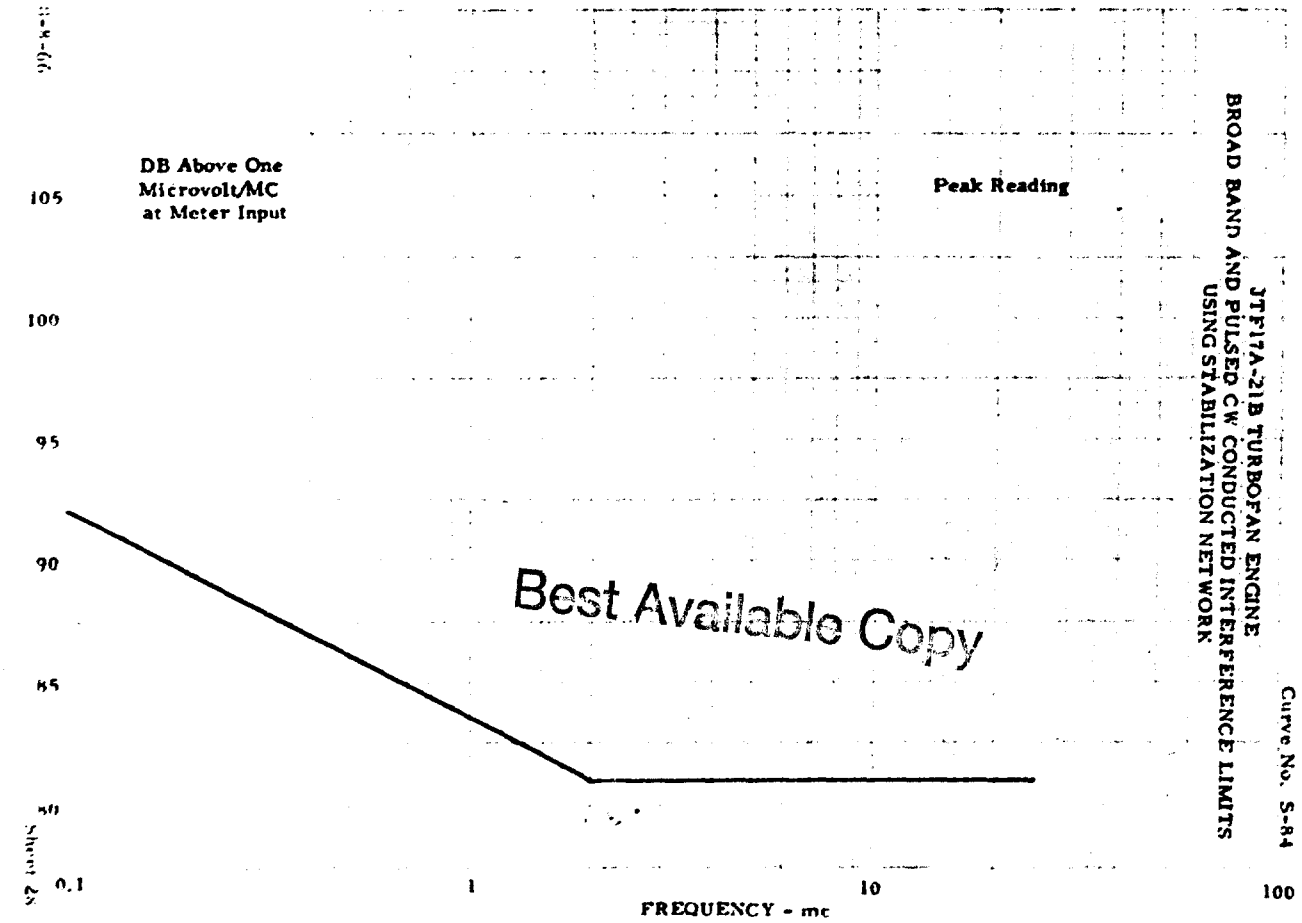
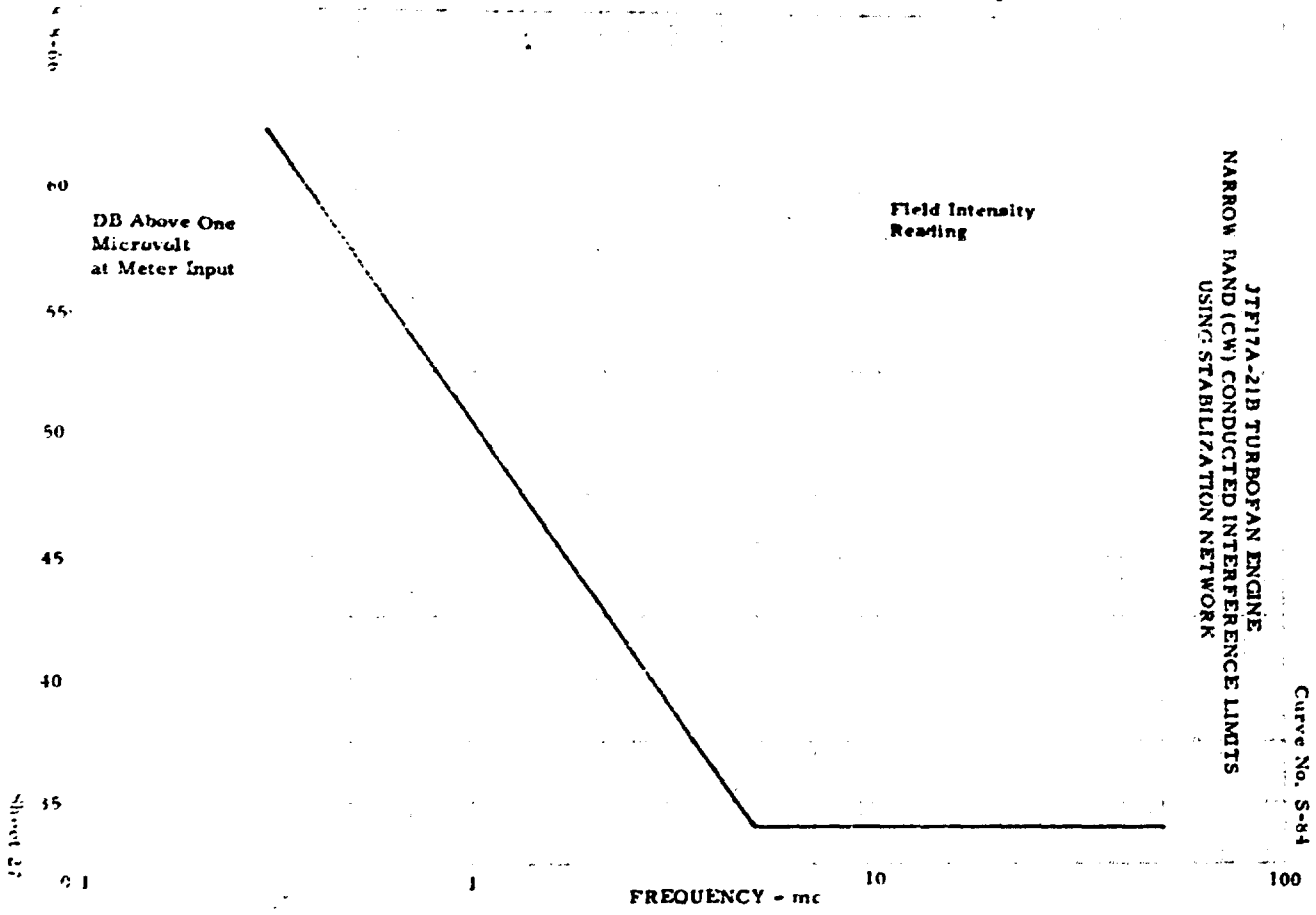

Pratt & Whitney Aircraft
Specification No. 2710

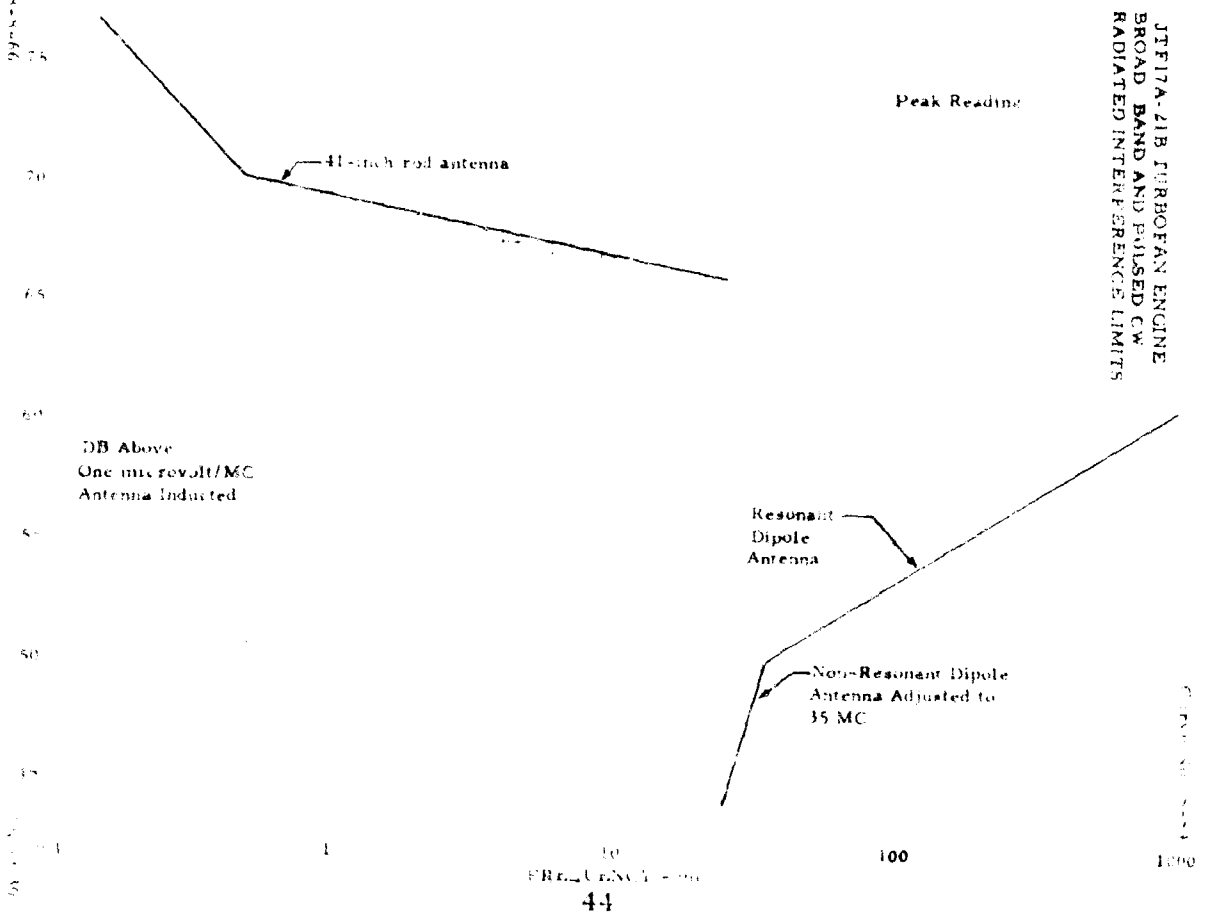
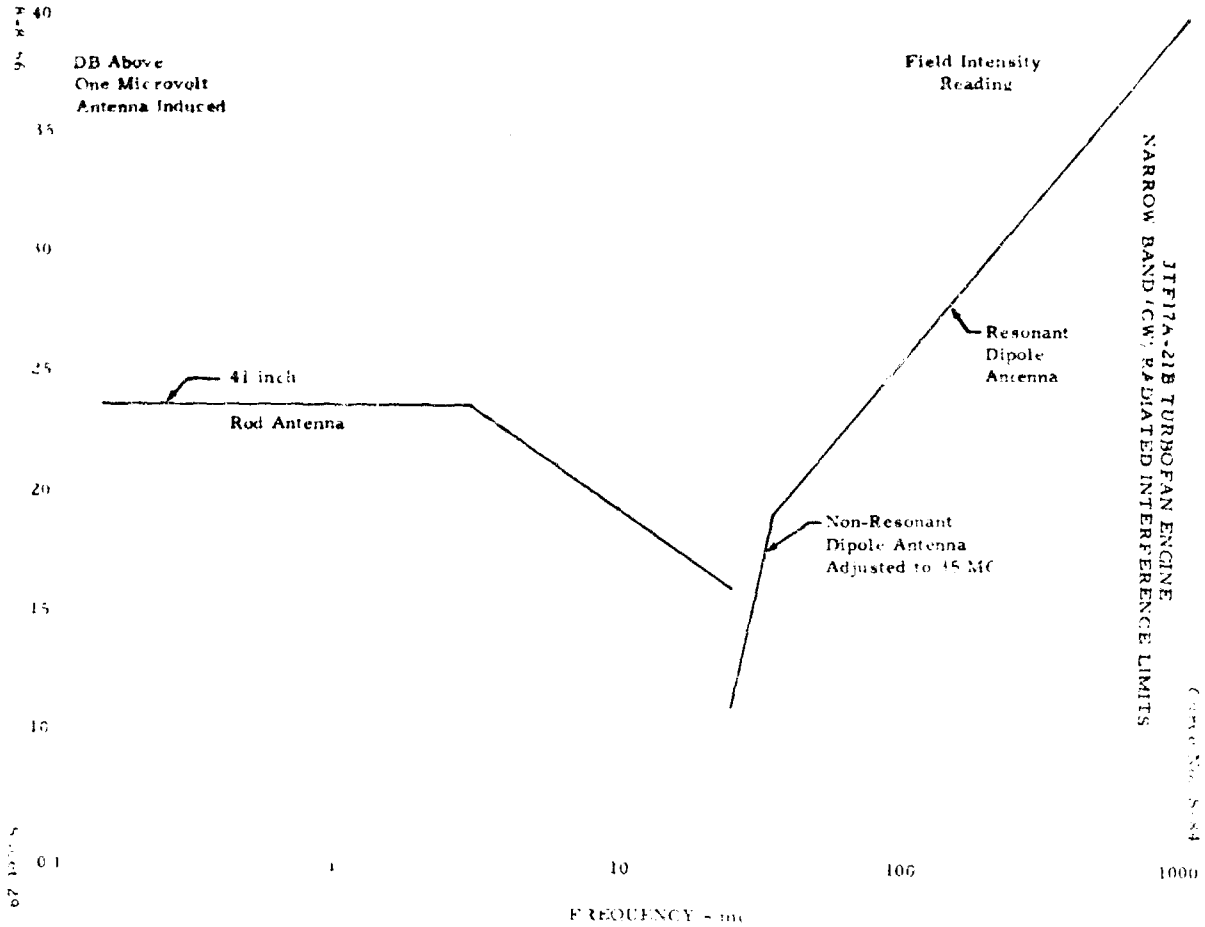

Pratt & Whitney Aircraft
Specification No. 2710

Curve No. S-84

JTF17A 3 TURBOFAN ENGINE
ESTIMATED ENVIRONMENTAL PRESSURE RECOVERY PER SHEET 5

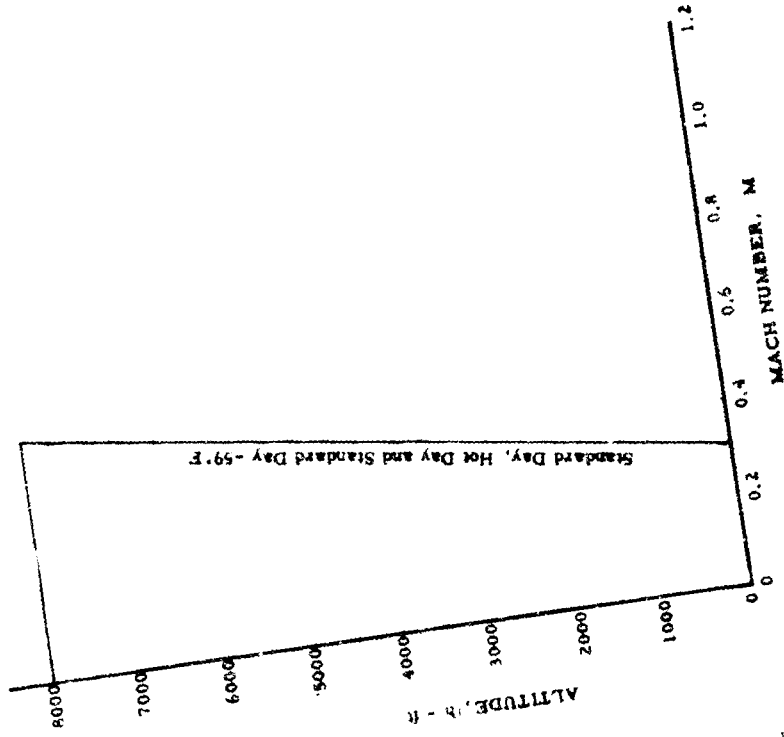

Sheet 32

Curve No. S-84

JTF17A 3 TURBOFAN ENGINE
MAXIMUM ALLOWABLE ESTIMATED CASE
TEMPERATURE VS ENGINE LENGTH

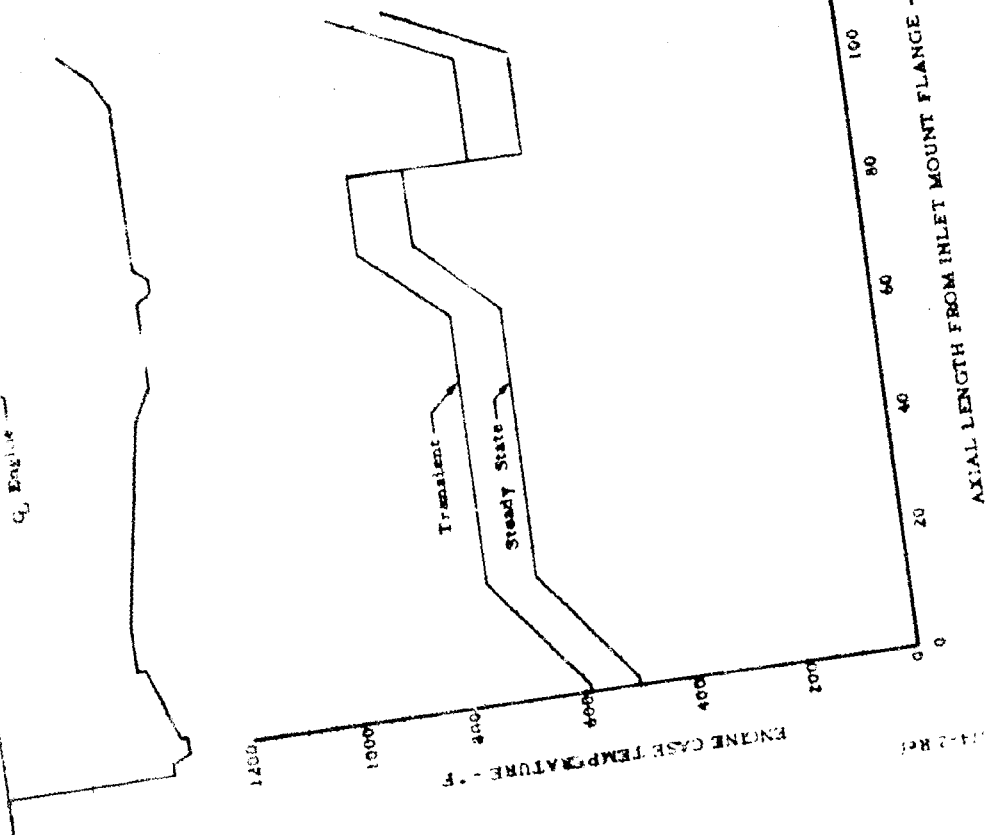

DF 49254 Ref
K-8-66

Sheet 31

Pratt & Whitney Aircraft
Specification No. 2710

Curve No. 5-24

JTF17A-21B TURBOFAN ENGINE
 ESTIMATED MAXIMUM NET REVERSE THRUST
 VS
 MACH NUMBER
 STANDARD DAY + 27°F
 INLET PRESSURE RECOVERY PER SHEET 5
 NO BLEED OR POWER EXTRACTION

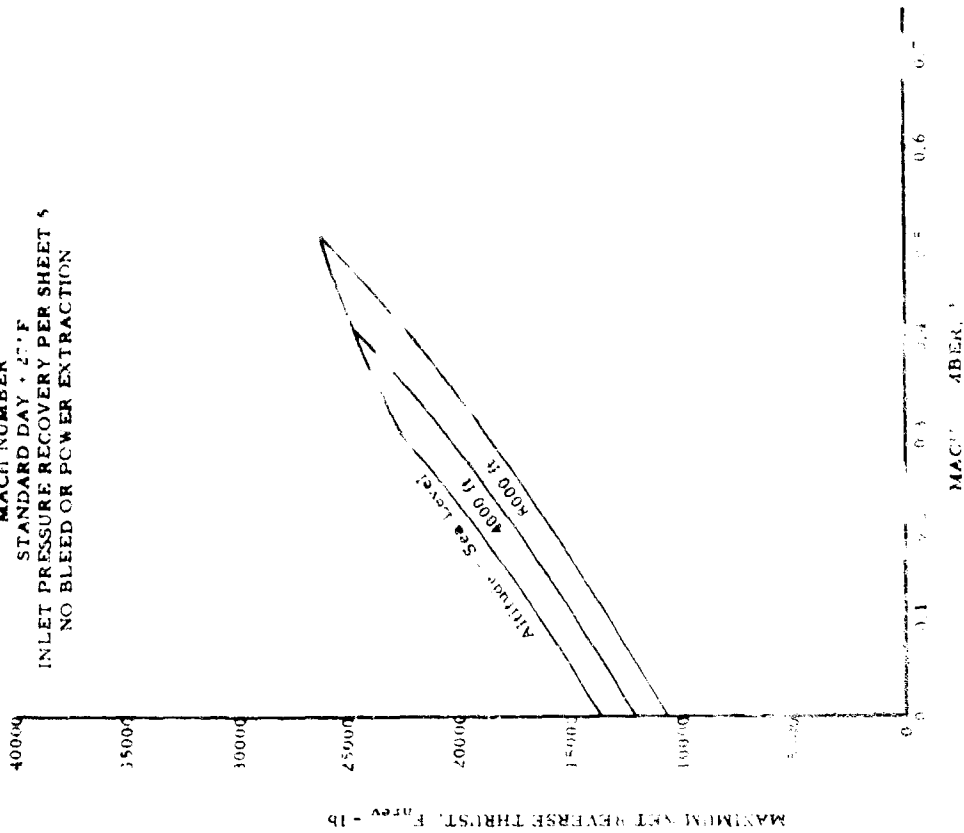

Sheet 14

Curve No. 5-24

JTF17A-21B TURBOFAN ENGINE
 ESTIMATED MAXIMUM NET REVERSE THRUST
 VS
 MACH NUMBER
 STANDARD DAY TO STANDARD -59°F DAY
 INLET PRESSURE RECOVERY PER SHEET 5
 NO BLEED OR POWER EXTRACTION

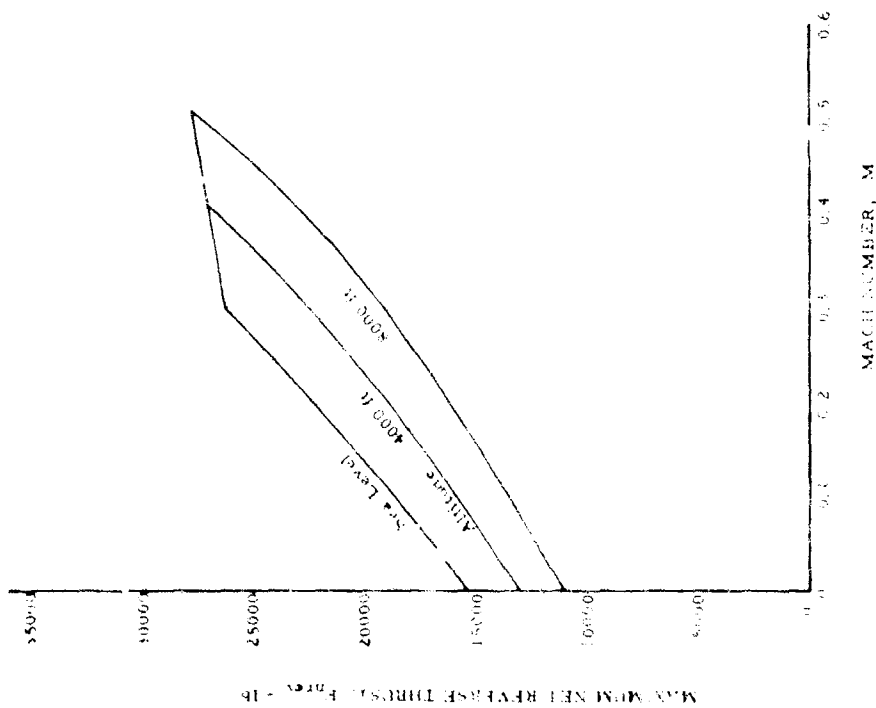

Curve No. 504

JTF17A-21B TURBOFAN ENGINE
ESTIMATED MAXIMUM AUGMENTED THRUST
1962 U. S. STANDARD ATMOSPHERE (GEOMETRIC)
INLET PRESSURE RECOVERY PER SHEET 5
REFER TO SHEET 2 FOR OPERATING LIMITS
CORRECTED SECONDARY AIRFLOW RATIO IS 0.02

Altitude - 55,000 to 80,000 feet

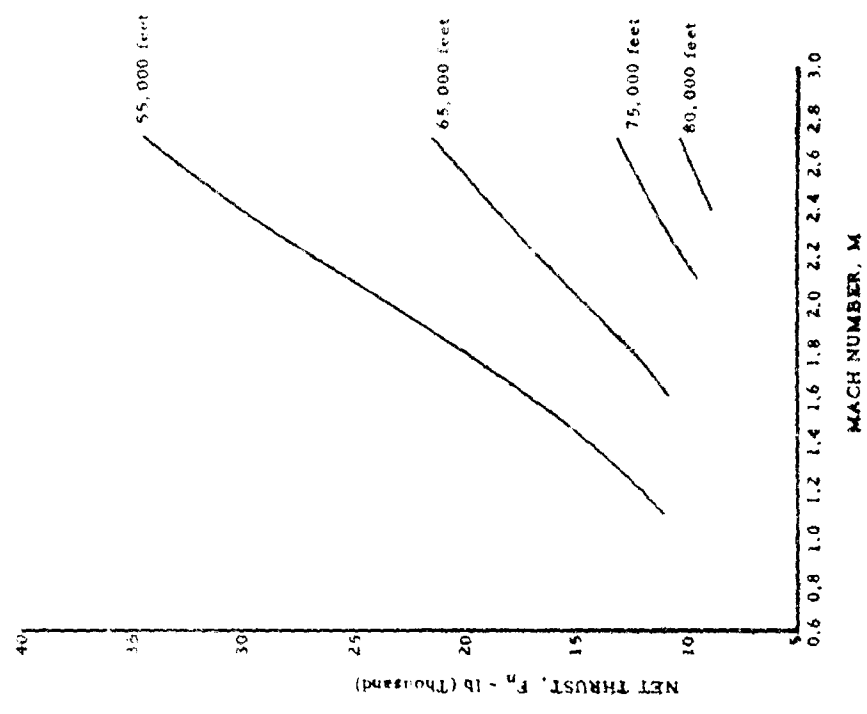

Sheet 36

Curve No. 505

JTF17A-21B TURBOFAN ENGINE
ESTIMATED MAXIMUM AUGMENTED THRUST
1962 U. S. STANDARD ATMOSPHERE (GEOMETRIC)
INLET PRESSURE RECOVERY PER SHEET 5
REFER TO SHEET 2 FOR OPERATING LIMITS
CORRECTED SECONDARY AIRFLOW RATIO IS 0.02

Sea Level to 45,000 feet

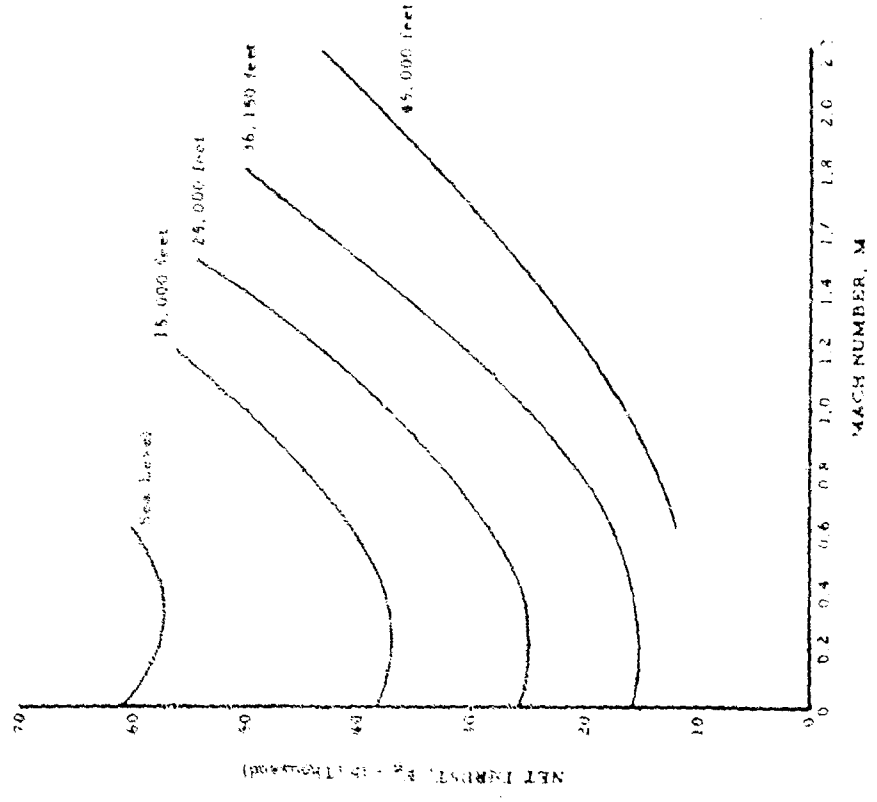

Sheet 35

Pratt & Whitney Aircraft Specification No. 2710

Pratt & Whitney Aircraft
Specification No. 2710

Curve No. 5-84

JTF17A-21B TURBOFAN ENGINE
ESTIMATED PARTIALLY AUGMENTED PERFORMANCE
1962 U. S. STANDARD ATMOSPHERE (GEOMETRIC)
INLET PRESSURE RECOVERY PER SHEET 5
REFER TO SHEET 2 FOR OPERATING LIMITS
CORRECTED SECONDARY AIRFLOW RATIO IS 0.02

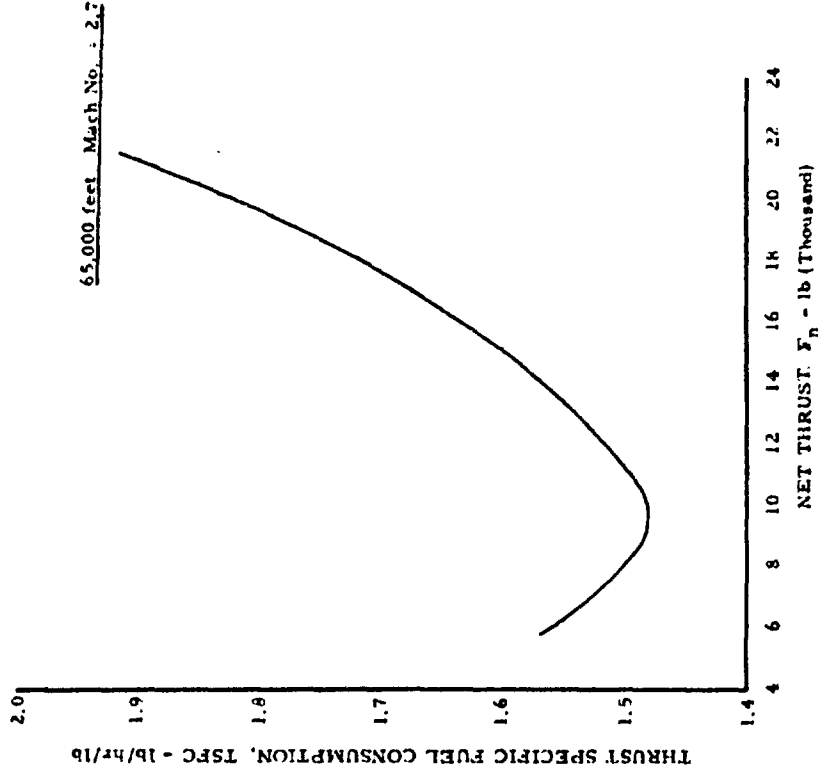

Curve No. 5-84

JTF17A-21B TURBOFAN ENGINE
ESTIMATED MAXIMUM AUGMENTED TSFC
1962 U. S. STANDARD ATMOSPHERE (GEOMETRIC)
INLET PRESSURE RECOVERY PER SHEET 5
REFER TO SHEET 2 FOR OPERATING LIMITS
CORRECTED SECONDARY AIRFLOW RATIO IS 0.02

Sea Level to 80,000 ft

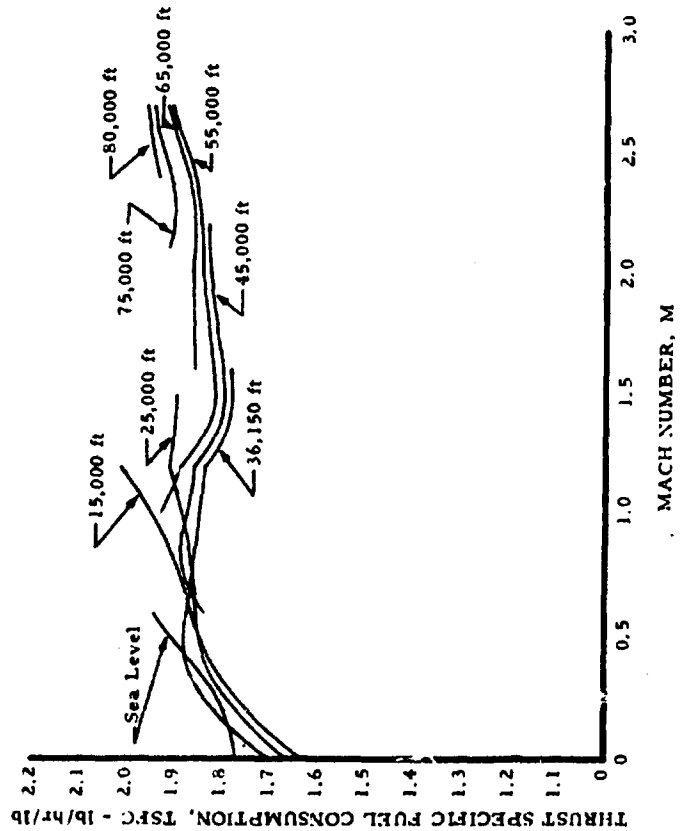

Best Available Copy

JTF17A-21B TURBOFAN ENGINE
GROUND AMBIENT TEMPERATURE ENVELOPE
ALTITUDE VS TEMPERATURE

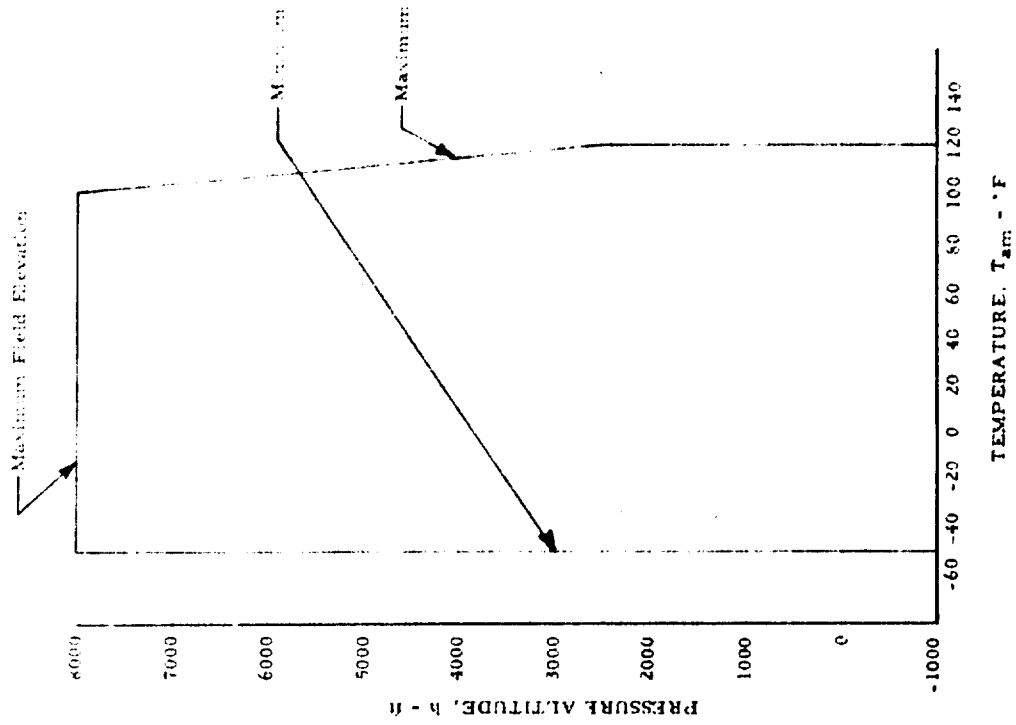

JTF17A-21B TURBOFAN ENGINE
FLIGHT AMBIENT TEMPERATURE ENVELOPE
ALTITUDE VS TEMPERATURE

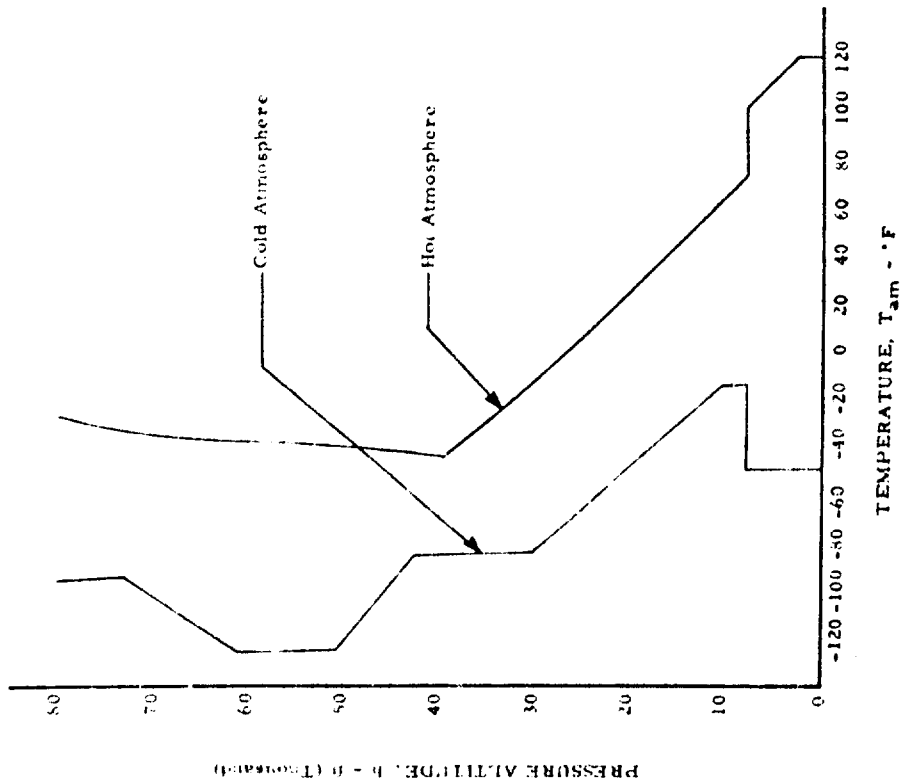

Sheet 39 5-5-66

Best Available Copy

PRESSURE SENSING (C)

EXIT PRESSURE 5625-INUMS-3A

MISCELLANEOUS

- AK 1420 GAL CAPACITY
- FUEL PUMP
- FUEL PUMP FILTER (C)
- HEATER FUEL OIL COOLER PRESSURE BY PASS VALVE
- WATER FUEL PUMP
- CD PUMP
- PRESSURE REGULATING VALVE
- WATER (C)
- FUEL OIL COOLER
- WATER FUEL OIL COOLER
- GEARBOX
- PROP GEARBOX
- PROP PRESSURIZING VALVE
- PRESSURE BLEED AIR PAD (C)
- FUEL CONTROL (MAIN AUGMENTATION, & NOZZLE)
- FUEL TUNING/PROP CONTROL VALVE
- JET PASSAGE
- TRAINING COMPARTMENT STRUT OIL SUMP

- FR (MAIN & JET IGNITION) 2 REQ'D
- FLUG (MAIN) 2 REQ'D (C)
- FLUG (JET HEATER) 2 REQ'D (C)
- FRONT MOUNT PROVISIONS (A)
- REAR MOUNT PROVISIONS (A)

- RETURN TO AIRFRAME FUEL SYSTEM (A)
- HANDLING AREA (FRONT) (A)
- HANDLING AREA (REAR) (A)

- WATER NOZZLE (FOR USE AS A WASHDOWN ELECTRICAL)
- PRESSURE BLEED AIR PAD (C)
- JET TEMP THERM 2 REQ'D (C)
- WATER ELECTRICAL CONNECTION (2 PLACES) (C)
- ELECTRIC POWER (2) (C)
- WATER PUMP (2) (C)
- WATER PUMP ELECTRICAL CONNECTION (ELECTRICAL)
- WATER NOZZLE (FOR USE AS A WASHDOWN)
- WATER VALVE (FOR HEATER ZONE II)
- WATER VALVE (FOR HEATER ZONE II)
- FUEL FLOWMETER (FOR MAIN AUGMENTATION) (C)
- WATER FUEL FLOWMETER (FOR MAIN AUGMENTATION) (C)
- WATER FUEL FILTER (C)
- WATER VALVE (MAIN FUEL)

- SERVO MOTOR (FOR MAIN AUGMENTATION) (ELECTRICAL)
- FUEL VALVE (VENT) (FOR MAIN AUGMENTATION)
- PROP INTERMEDIATE INFLATOR (HEATER) (C)
- PROP INTERMEDIATE INFLATOR (FOR MAIN AUGMENTATION)
- PROP INTERMEDIATE INFLATOR (FOR MAIN AUGMENTATION)
- PROP INTERMEDIATE INFLATOR (FOR MAIN AUGMENTATION)

- MOTOR ROTATION ACCESS PAD
- SHAFT DISengagement ACCESS PAD

- MARY AIR INFLATOR (1) (A REQ'D)

- CONTROL (REMOTE ADJUSTMENT) (ELECTRICAL)
- MOTOR SPEED INDICATION (ELECTRICAL) (K)

- INSPECTION PORT (2 REQ'D)
- WATER HOUSING (ACTUATOR) (4 REQ'D)
- BURNER INSPECTION PORT (2 REQ'D)
- WATER AND ACCESS PORTS (K)

- DYNAMIC BRAKE ACTUATOR (2 REQ'D)
- ESCAP INSPECTION PORT (15 REQ'D)
- ESCAP THROTTLE ACTUATOR (2 REQ'D)
- MICROVALVE FILTER (C)
- HEATER FUEL PUMP AIR EXHAUST
- REVERSE INTERLOCK PULLY

- PROP BLEED PILOT VALVE
- STRAINER (C) (DUCT HEATER ZONE II) (4 PLACES)
- BURNER PRESSURE SENSE 5625-INUMS-3A (C) (14 REQ'D)
- AIR PRESSURE SENSE TOTAL 5625-INUMS-3A (C) (14 REQ'D)
- AIR PRESSURE SENSE STATIC 5625-INUMS-3A (C) (14 REQ'D)
- MARY AIR VALVE POSITION INDICATOR ELECTRICAL CONNECTOR
- MARY AIR VALVE POSITION INDICATOR ELECTRICAL CONNECTOR
- MARY AIR DUCT VALVE ACTUATOR
- DYNAMIC BRAKE POSITION VALVE
- DYNAMIC BRAKE POSITION VALVE ELECTRICAL CONNECTOR
- DYNAMIC BRAKE POSITION VALVE AIR SUPPLY 750-INUMS-3B (C)
- DYNAMIC BRAKE POSITION VALVE AIR VENT 750-INUMS-3B (C) (14)

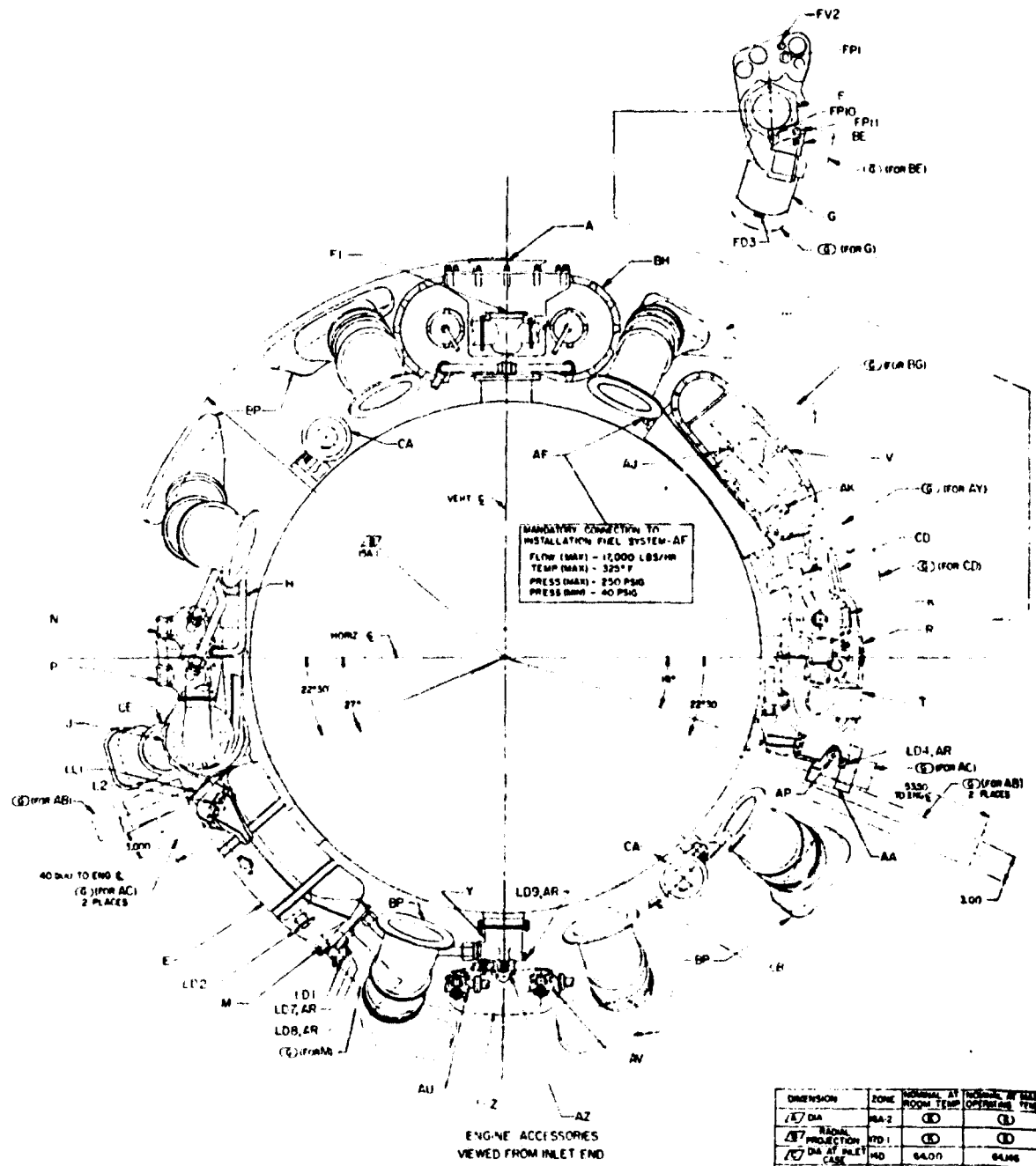

MANDATORY CONNECTION TO
INSTALLATION FUEL SYSTEM-AF
FLOW (MAX) - 12,000 LBS/HR
TEMP (MAX) - 325° F
PRESS (MAX) - 250 PSIG
PRESS (MIN) - 40 PSIG

ENGINE ACCESSORIES
VIEWED FROM INLET END

DIMENSION	ZONE	MINIMUM AT ROOM TEMP	MINIMUM AT MAX OPERATING TEMP
DA	AA-2	(C)	(C)
DA	AA-1	(C)	(C)
DA AT INLET CASE	MD	64.00	64.06
DA	22E-3	(C)	(C)
DA AT FRONT OF CASE	AC-4	72.00	72.84
LENGTH	BF-1	22.789	(C)
DA	AC-1	80.00	80.32
HEIGHT	4C	95.136	(C)

2129601

Best Available Copy

B

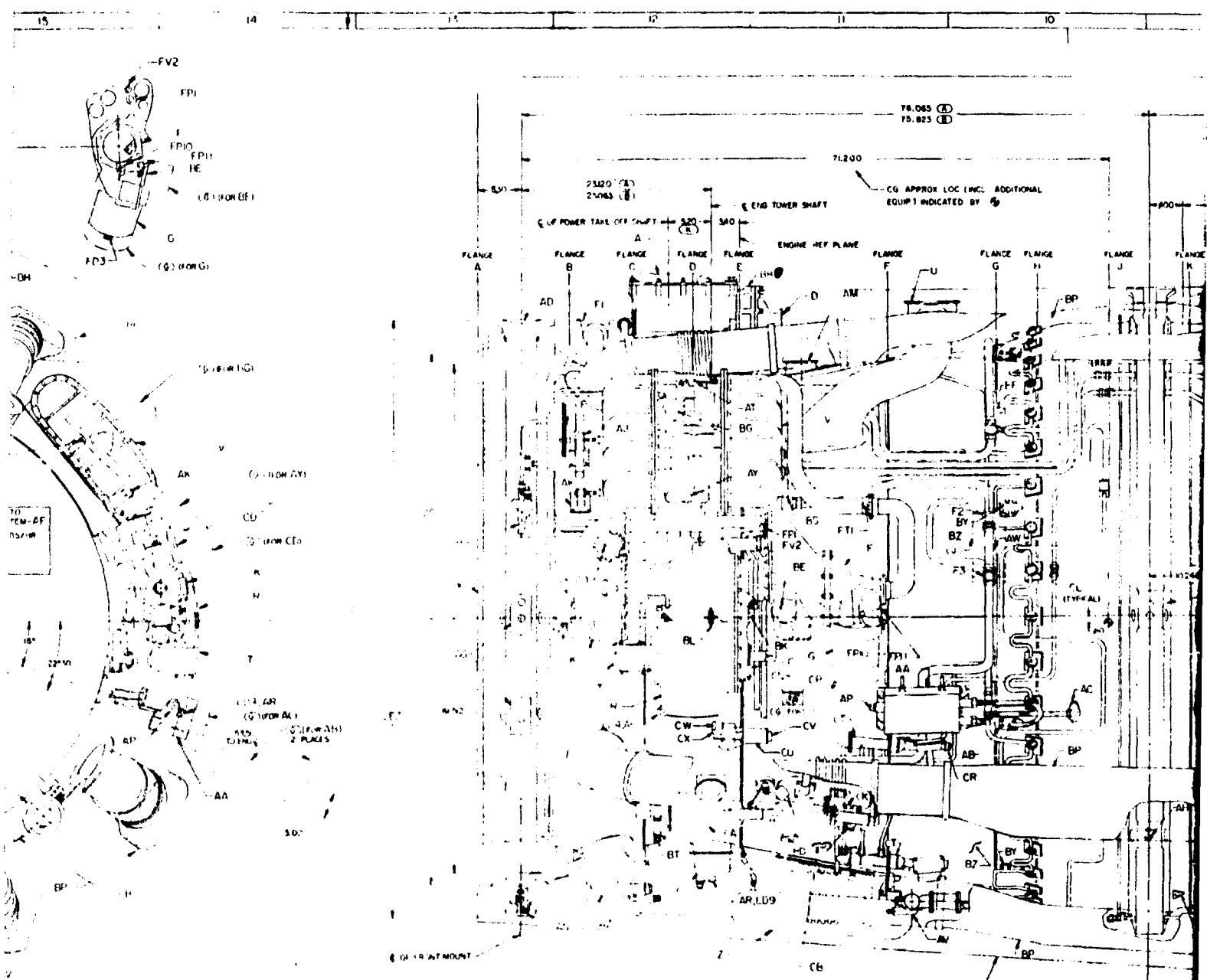

DIMENSION	ZONE	NORMAL AT		ENG WILL NOT EXCEED		DESCRIPTION
		ROOM TEMP	OPERATING TEMP	AT ROOM TEMP	AT ROOM TEMP	
1) DIA	EA-2	(E)	(E)	(E)	(E)	DIA OF LARGEST CIRCLE CONC WITH ENG AXIS INCLUDING LOCAL RADIAL PROJECTIONS INCLUDING AROUND FULL ENCLOSURE OF ENG EXCLUDING REMOVER SUPPRESSOR
2) RADIAL PROJECTION	FD-1	(E)	(E)	(E)	(E)	LARGEST LOCAL RADIAL PROJECTION FROM E OF ENG INCLUDING R/S
3) DIA AT ALET CASE	4D	44.31	64.148	64.06L	(E)	ALET CASE FLOWTH DIA INCLUDING SECONDARY AIR FLOW
4) DIA	22F-5	K	(E)	(E)	(E)	R/S DIA AT A/F MATEUP
5) DIA AT FRONT MOUNT RING	4C-1	72.00	72.888	72.050	(E)	BASIC RING DIA EXCLUDING ATTACHMENT
6) LENGTH	8F-1	20.789	(E)	(E)	(E)	LARGEST AXIAL LENGTH OF ENG
7) DIA	4E-1	80.00	80.32	(E)	(E)	R/S DIA CONC WITH THRUST AXIS
8) HEIGHT	4C	85.156	(E)	(E)	(E)	R/S OVERALL HEIGHT NORMAL TO INTERNAL E OF ENG

NOTE:
SPACE INSIDE THIS ENVELOPE RESERVED FOR ENGINE. ANY USE OF THIS AREA FOR AIRFRAME EQUIPMENT SHALL BE PERMITTED ONLY AFTER SPECIFIC COORDINATION WITH P&W.

2129601 1/1

Best Available Copy

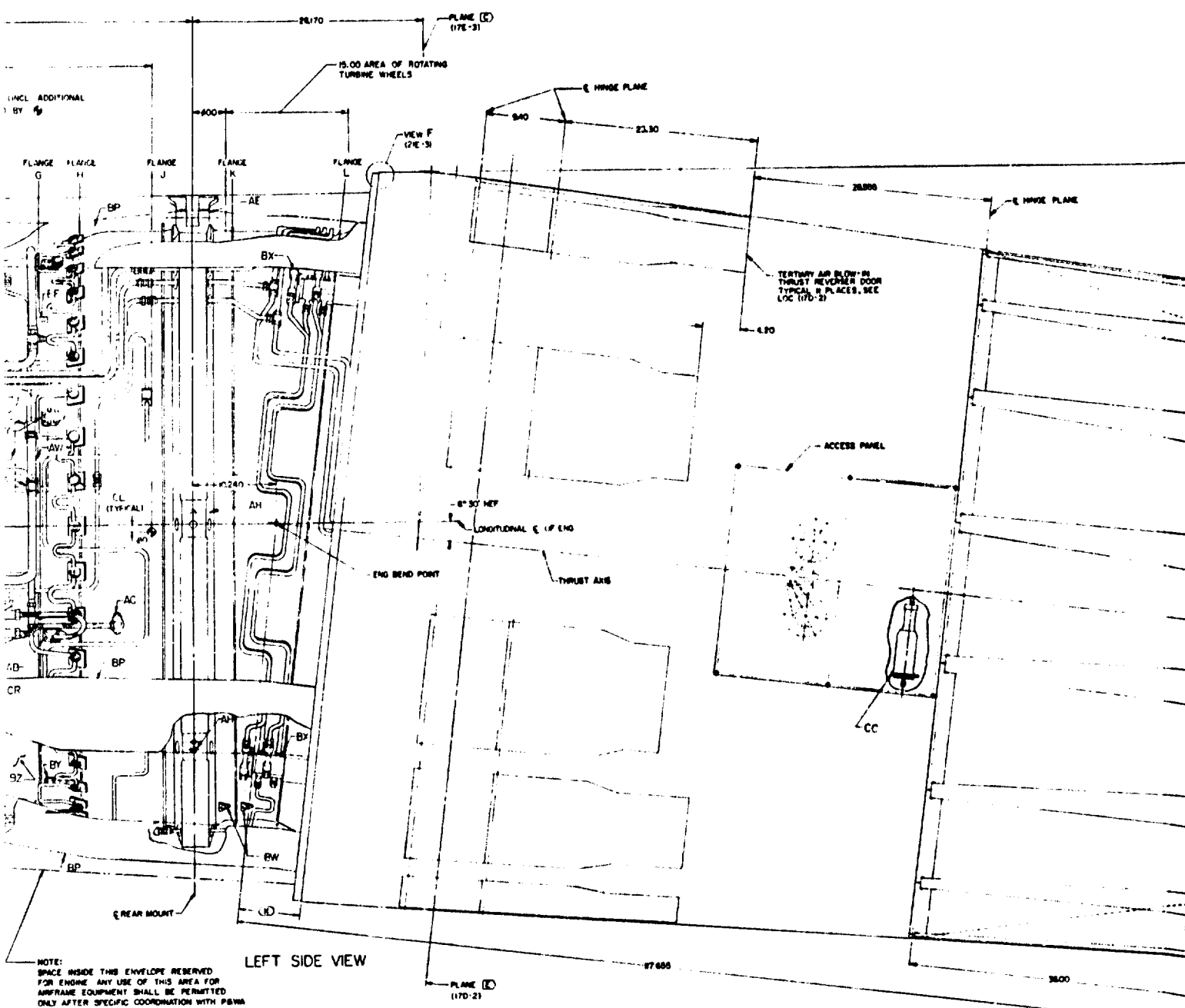
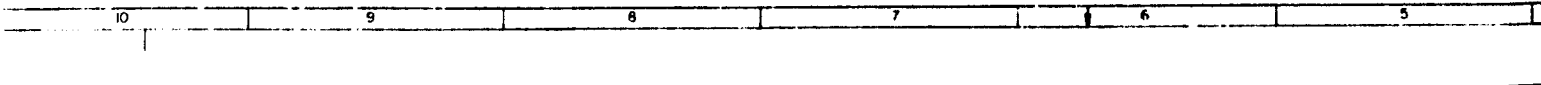

NOTE:
 SPACE INSIDE THIS ENVELOPE RESERVED
 FOR ENGINE. ANY USE OF THIS AREA FOR
 AIRFRAME EQUIPMENT SHALL BE PERMITTED
 ONLY AFTER SPECIFIC COORDINATION WITH P8WA

LEFT SIDE VIEW

2129601

Best Available Copy

D

Pratt & Whitney Aircraft
Specification No. 2710

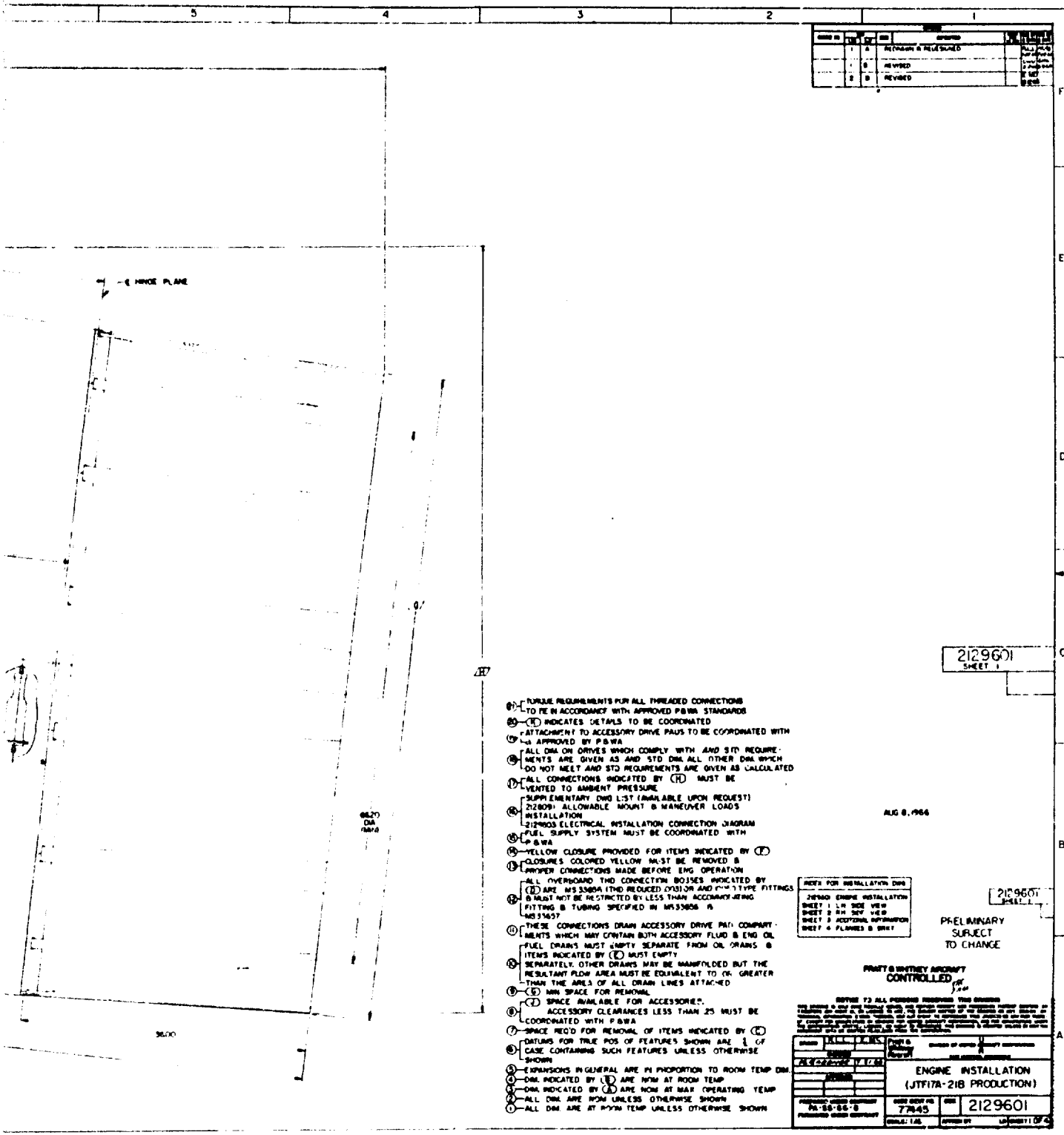

REV	DATE	BY	DESCRIPTION
1			REVISION & RESCHEDULE
2			REVISED
3			REVISED

2129601
SHEET 1

- ①-TURBO REQUIREMENTS FOR ALL THREADED CONNECTIONS TO BE IN ACCORDANCE WITH APPROVED P&WA STANDARDS
- ②-④ INDICATES DETAILS TO BE COORDINATED
- ⑤-ATTACHMENT TO ACCESSORY DRIVE PADS TO BE COORDINATED WITH APPROVED BY P&WA
- ⑥-ALL DIM ON DRIVES WHICH COMPLY WITH AND STD REQUIREMENTS ARE GIVEN AS AND STD DIM ALL OTHER DIM WHICH DO NOT MEET AND STD REQUIREMENTS ARE GIVEN AS CALCULATED
- ⑦-ALL CONNECTIONS INDICATED BY (C) MUST BE VENTED TO AMBIENT PRESSURE
- ⑧-SUPPLEMENTARY DIM LIST (AVAILABLE UPON REQUEST)
- ⑨-22800: ALLOWABLE MOUNT & MANEUVER LOADS INSTALLATION
- ⑩-2129603 ELECTRICAL INSTALLATION CONNECTION DIAGRAM FUEL SUPPLY SYSTEM MUST BE COORDINATED WITH P&WA
- ⑪-YELLOW CLOSURE PROVIDED FOR ITEMS INDICATED BY (C)
- ⑫-CLOSURES COLORED YELLOW MUST BE REMOVED BEFORE CONNECTIONS MADE BEFORE ENG OPERATION
- ⑬-ALL OVERBOARD TMD CONNECTION BOSSIES INDICATED BY (C) ARE MS3508A (TMD REDUCED O/D) AND (C) TYPE FITTINGS MUST NOT BE RESTRICTED BY LESS THAN ACCESSORY TMD FITTING & TUBING SPECIFIED IN MS3508A
- ⑭-ALL THESE CONNECTIONS DRAIN ACCESSORY DRIVE PART COMPANY ELEMENTS WHICH MAY CONTAIN BOTH ACCESSORY FLUID & ENG OIL FUEL DRAINS MUST EMPTY SEPARATE FROM OIL DRAINS & ITEMS INDICATED BY (C) MUST EMPTY SEPARATELY OTHER DRAINS MAY BE MANIFOLDED BUT THE RESULTANT FLOW AREA MUST BE EQUIVALENT TO OR GREATER THAN THE AREA OF ALL DRAIN LINES ATTACHED
- ⑮-⑯ MIN SPACE FOR REMOVAL
- ⑰-SPACE AVAILABLE FOR ACCESSORIES
- ⑱-ACCESSORY CLEARANCES LESS THAN 25 MUST BE COORDINATED WITH P&WA
- ⑲-SPACE REQD FOR REMOVAL OF ITEMS INDICATED BY (C)
- ⑳-DIMENSIONS FOR TRUE POS OF FEATURES SHOWN ARE 1/2 OF CASE CONTAINING SUCH FEATURES UNLESS OTHERWISE SHOWN
- ㉑-DIMENSIONS IN GENERAL ARE IN PROPORTION TO ROOM TEMP DIM
- ㉒-DIM INDICATED BY (C) ARE NOM AT ROOM TEMP
- ㉓-DIM INDICATED BY (D) ARE NOM AT MAX OPERATING TEMP
- ㉔-ALL DIM ARE NOM UNLESS OTHERWISE SHOWN
- ㉕-ALL DIM ARE AT ROOM TEMP UNLESS OTHERWISE SHOWN

AUG 8, 1966

INDEX FOR INSTALLATION DIMS
2129601 ENGINE INSTALLATION
SHEET 1 LR SIDE VIEW
SHEET 2 RH SIDE VIEW
SHEET 3 ACCESSORY INFORMATION
SHEET 4 FLOWED & DRY

2129601
SHEET 1

PRELIMINARY
SUBJECT
TO CHANGE

PRATT & WHITNEY AIRCRAFT
CONTROLLED

OTHER TO ALL OPERATIONS THIS DRAWING

THIS DRAWING IS THE PROPERTY OF PRATT & WHITNEY AIRCRAFT COMPANY AND IS LOANED TO YOU FOR YOUR INFORMATION ONLY. IT IS NOT TO BE REPRODUCED OR TRANSMITTED IN ANY FORM OR BY ANY MEANS, ELECTRONIC OR MECHANICAL, INCLUDING PHOTOCOPYING, RECORDING, OR BY ANY INFORMATION STORAGE AND RETRIEVAL SYSTEM, WITHOUT THE WRITTEN PERMISSION OF PRATT & WHITNEY AIRCRAFT COMPANY.

GROUP	ALL	CLASS	GROUP	GROUP
DATE	2129601	DATE	DATE	DATE
REVISED		REVISED	REVISED	REVISED
PREPARED BY	77845	DATE	2129601	DATE
APPROVED BY		DATE		DATE

ENGINE INSTALLATION
(JTF17A-21B PRODUCTION)

E

RTUARY AIR BLOW-IN DOORS
 2 PLACES 8 PLACES 22", 3 PLACES 20"

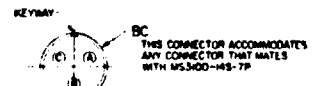
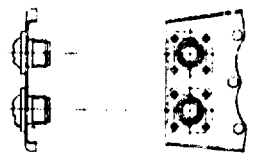
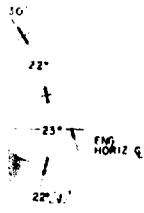

REVERSE POSITION TRANSDUCER CONNECTOR
 SCHEMATIC OF PIN DESIGNATION
 SCALE: NONE

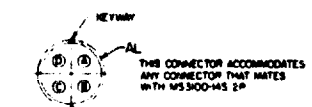

DUCT HEATER NOZZLE POSITION TRANSDUCER CONNECTOR
 SCHEMATIC OF PIN DESIGNATION
 SCALE: NONE

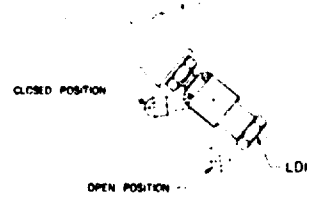

OLE TANK DRAIN LDI
 SCALE: NONE

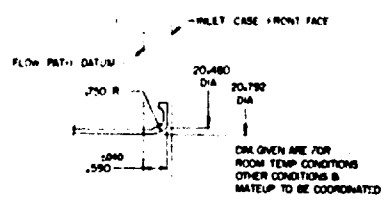
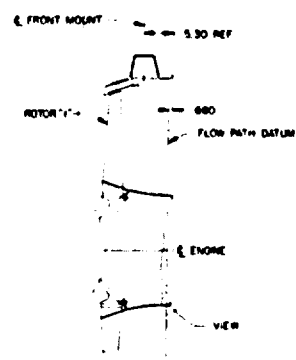

VIEW
 SCALE: 1/1
 INLET CENTERBODY FLOWPATH

SECTION B-B
 SCALE: 1/4

ALL BEARING TO MATE WITH THIS DIM. UNLESS SPECIFIED BY P/B MAY FIT TO BE (H) TO USE UNDER ANY CONDITIONS.

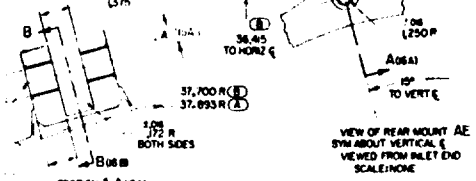

VIEW OF REAR MOUNT AE
 SYN ABOUT VERTICAL E
 VIEWED FROM INLET END
 SCALE: NONE

SECTION A-A (15A)
 2 PLACES
 SCALE: 1/2

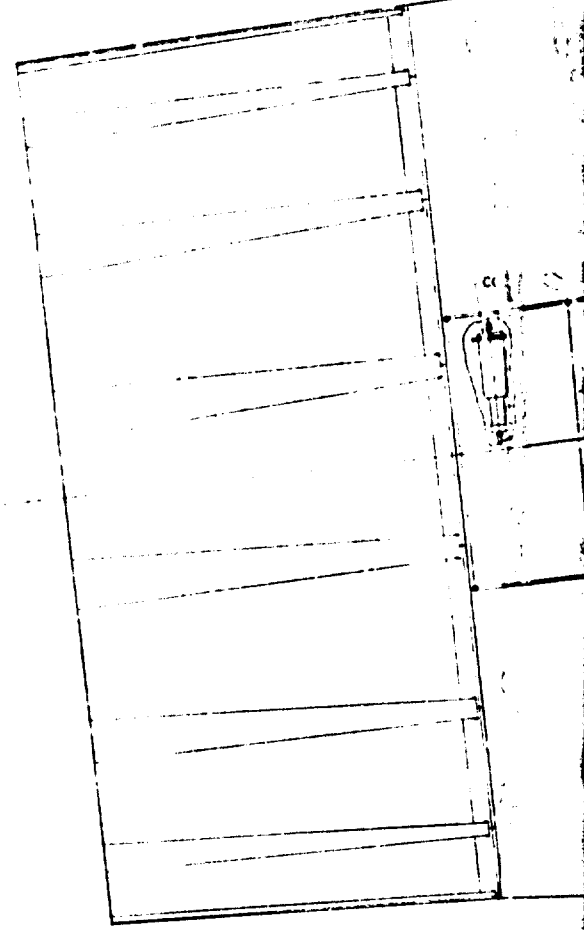

Best Available Copy

C

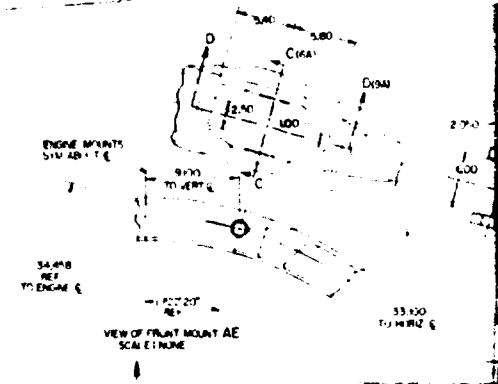
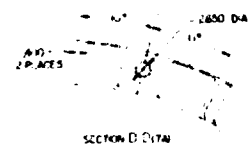
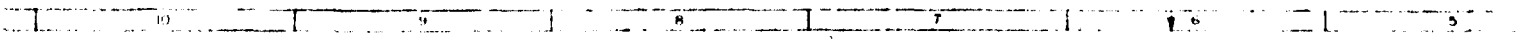

Best Available Copy

D

Pratt & Whitney Aircraft
Specification No. 2710

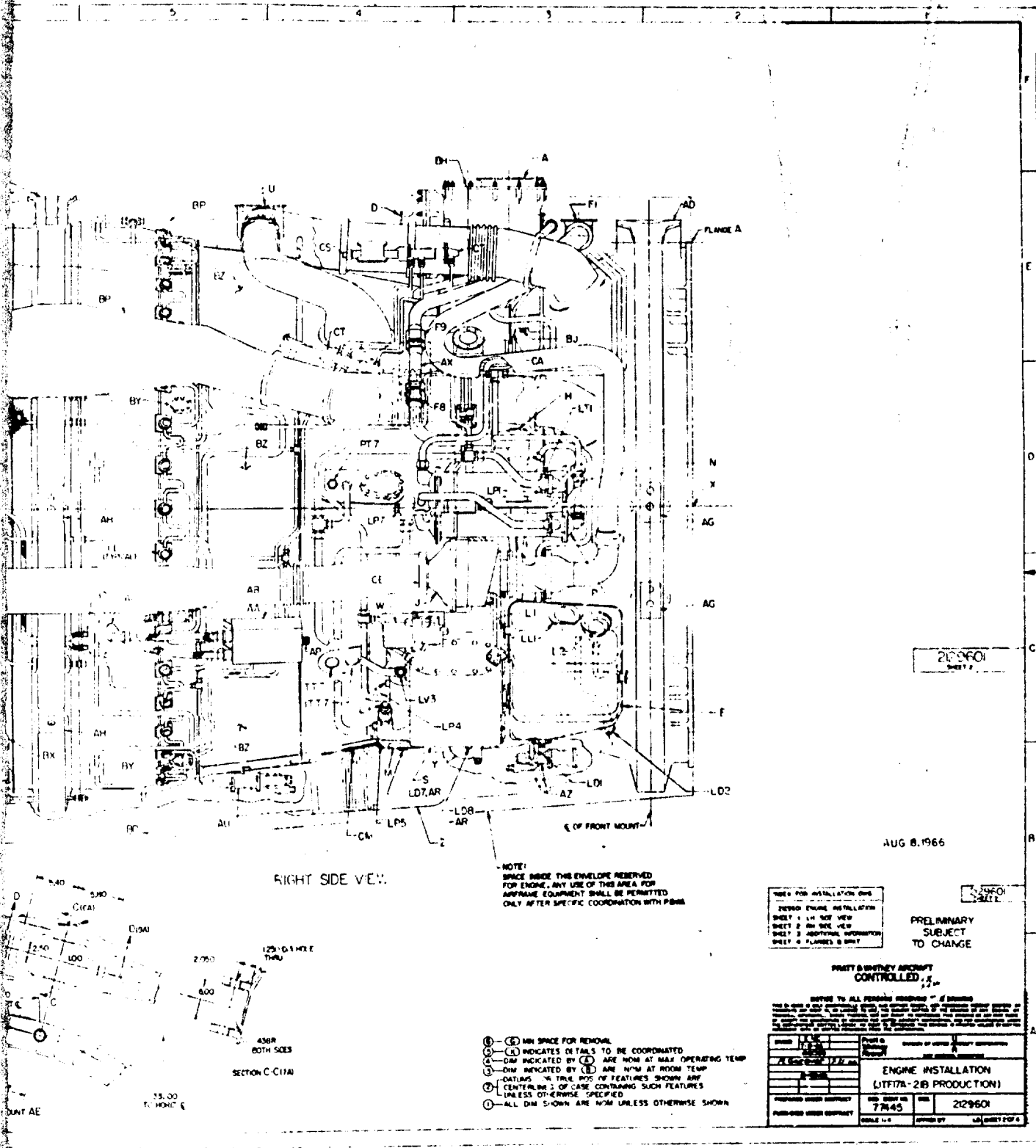

209601
SHEET 1

AUG 8, 1966

RIGHT SIDE VIEW

NOTE:
SPACE INSIDE THIS ENVELOPE RESERVED FOR ENGINE. ANY USE OF THIS AREA FOR AIRFRAME EQUIPMENT SHALL BE PERMITTED ONLY AFTER SPECIFIC COORDINATION WITH PMA.

THIS IS FOR INSTALLATION ONLY
PERIOD ENGINE INSTALLATION
SHEET 1 - R/S SIDE VIEW
SHEET 2 - L/S SIDE VIEW
SHEET 3 - ADDITIONAL INFORMATION
SHEET 4 - FLANGES & MOUNT

PRELIMINARY
SUBJECT
TO CHANGE

PRATT & WHITNEY AIRCRAFT
CONTROLLED

ENGINE INSTALLATION
(LIT17A-219 PRODUCTION)

DESIGNED BY	77845	REV	2129601
APPROVED BY		DATE	
ISSUED BY		BY	
DATE		BY	

- ① - ⑤ MIN SPACE FOR REMOVAL
- ⑥ - ⑧ INDICATES DETAILS TO BE COORDINATED
- ⑨ - DIM INDICATED BY ⑨ ARE NOM AT MAX OPERATING TEMP
- ⑩ - DIM INDICATED BY ⑩ ARE NOM AT ROOM TEMP
- ⑪ - DIM IN TRAIL POS OF FEATURES SHOWN ARE CENTERLINE ⑪ OF CASE CONTAINING SUCH FEATURES UNLESS OTHERWISE SPECIFIED
- ⑫ - ALL DIM SHOWN ARE NOM UNLESS OTHERWISE SHOWN

Best Available Copy

E

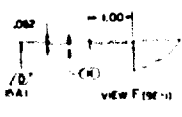
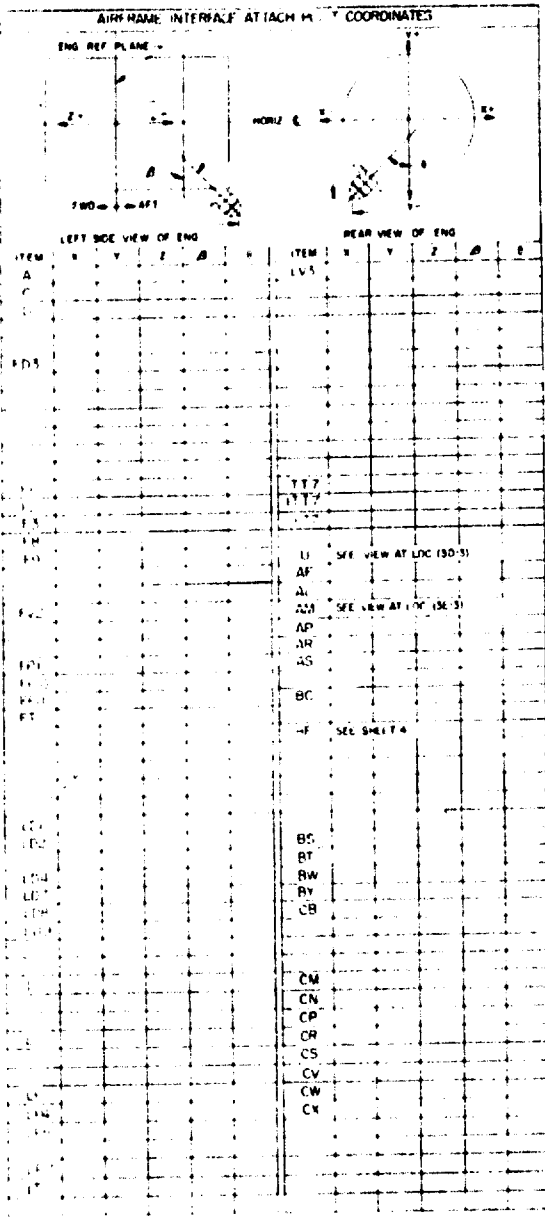

DETAILS OF REVERSER SUPPRESSOR
MATE-UP & LOC TO BE COORDINATED

NACELLE COWL REVERSER SUPPRESSOR MATE-UP ALLOWABLE LOAD
THE MAX ALLOWABLE LOADING AT MATEUP IS DEFINED BY (A)

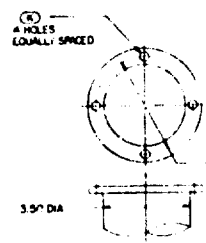

COMMON FUEL INLET FLANGE FI
SCALE: NONE
(DETAILS OF COUPLING, SEAL & ALLOWABLE
LOADS FOR COMMON FUEL INLET TO BE
COORDINATED)

THE ALLOWABLE LOAD AT FI SHALL BE DETERMINED BY
THE EQUATION (A) WHERE: M = MOMENT (LB IN)
P = AXIAL LOAD (LB)
V = SHEAR LOAD (LB)
T = TORQUE (IN IN) X R

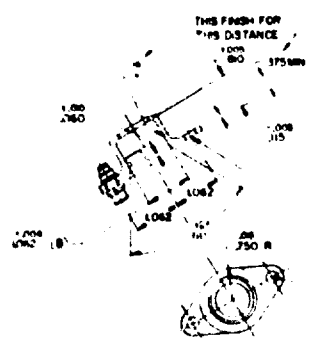

MAX ENVELOPE FOR
INTERNAL OIL QUANTITY
TRANSMITTER

1.00
2.81 DIA
2 HOLES
LOC WITHIN .005 R OF
TRUE POS & RELATION
TO DIA (B)

1.00
2.81 R
2 PLACES

OIL TANK OVEFLOW DRAIN CUTLET LD2

NOTE: DIMENSIONS TO BE PROVIDED WHEN AVAILABLE

Best Available Copy

A

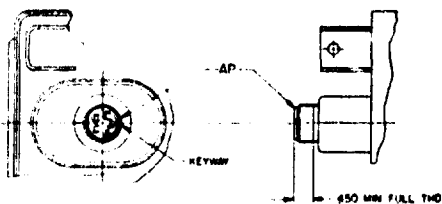

THIS CONNECTOR ACCOMMODATES ANY CONNECTOR THAT MATES WITH MS 102-145-59
 HANTRON LEXITER PLEO CONNECTOR SCHEMATIC OF PIN DESIGNATION

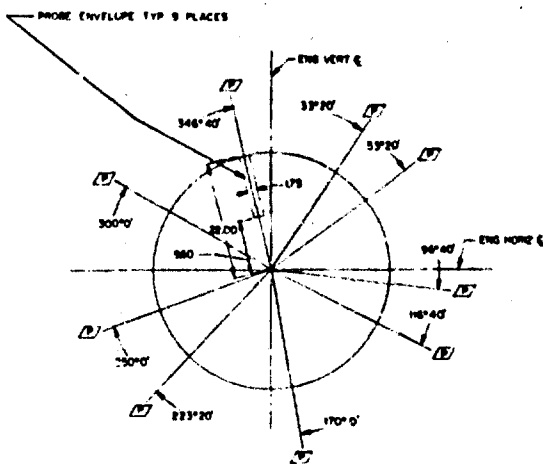

SCHEMATIC VIEW LOOKING FORWARD AT PLANE (D) (P-1)
 TURBINE ENT TEMPERATURE THERMOCOUPLES AT LOC INDICATED BY (E)

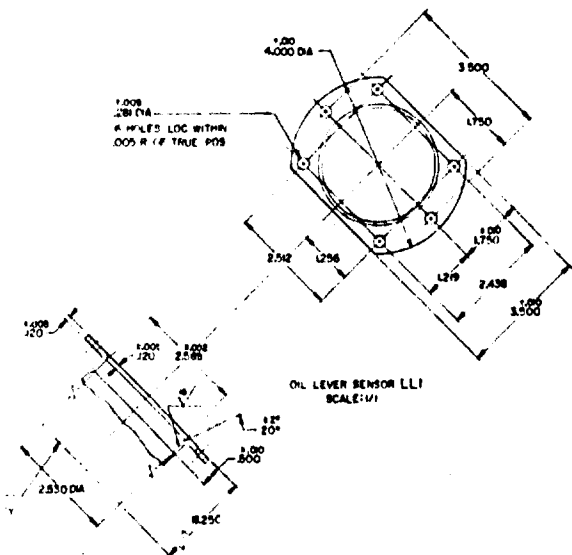

OIL LEVER SENSOR LLI
 SCALE: 1/1

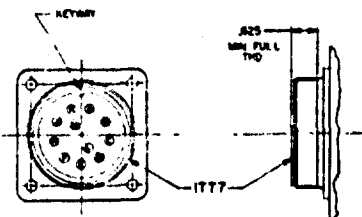

THIS CONNECTOR ACCOMMODATES ANY CONNECTOR THAT MATES WITH MS 300-20-33P
 TURBINE ENT TEMPERATURE THERMOCOUPLE SCHEMATIC OF PIN DESIGNATION SCALE: 2/1

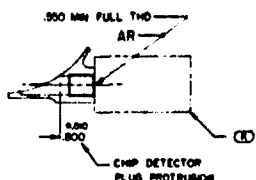

TYP CMP DETECTOR OTHER LOC (D)

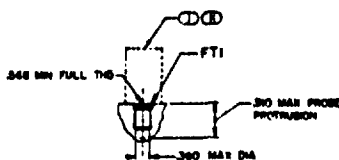

FUEL INLET TEMP FTI

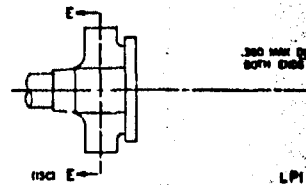

OIL PRESSURE TRANSMITTER & TEMPERATURE SENS
 1. TRANSMITTER MUST CONTAIN AN OIL THERM AND ISA AT ATTACHMENT TO IS
 2. MAX OPERATING OIL PRESSURE 48 PSI
 3. MAX OIL TEMP 320° F
 4. TRANSMITTER TO BE ENGINE MOUNTED PROVISIONS FOR ATTACHMENT (D)

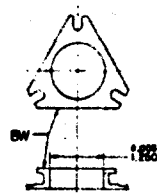

DETAILS OF TURBINE INSPECTION PORT & LOC (D)

TURBINE INSPECTION PORT

2129601

Best Available Copy

B

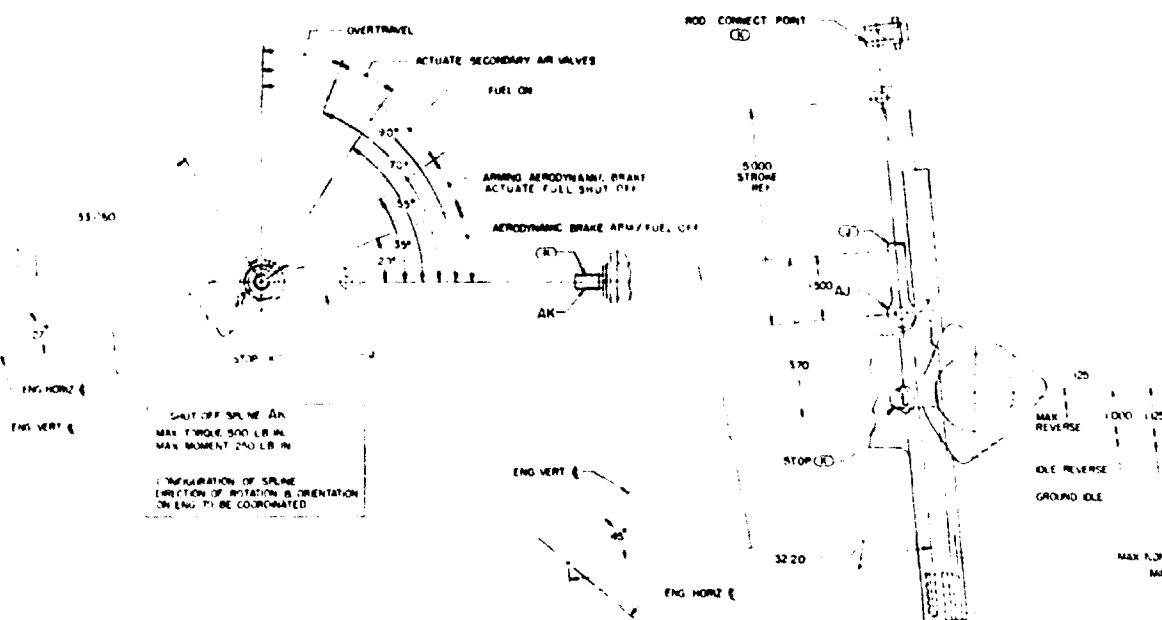

SHUT OFF SPRING AN
MAX TWIST 500 LB IN
MAX MOMENT 250 LB IN

COORDINATION OF SPRING
DIRECTION OF ROTATION & ORIENTATION
ON ENG TO BE COORDINATED

POWER ROD AJ
MAX PUSH-PULL 100 LB
AGAINST STOP
CONFIGURATION OF ATTACHMENT
DIRECTION OF POWER STROKE
TO BE COORDINATED

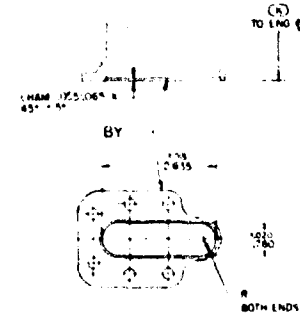
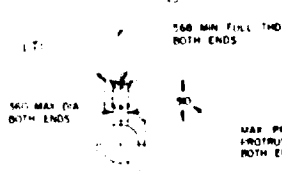
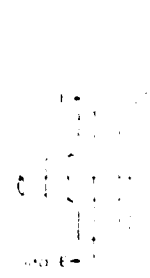

- SECTION E (140)
- PRESSURE TRANSDUCER & TEMPERATURE SENSING PROVISIONS
1. TRANSDUCER MUST CONTAIN AN ORIFICE NO LARGER THAN 0.002 DIA AT ATTACHMENT TO ENG CONNECTION
 2. MAX OPERATING CH PRESSURE 45 PSIG
 3. MAX OR TEMP 500°F
 4. TRANSDUCER TO BE ENGINE MOUNTED
- ENGINE SENS FOR ATTACHMENT W

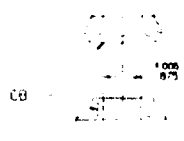

DETAILS OF COMPRESSOR INSPECTION PORTS & LOC (14)

COMPRESSOR INSPECTION PORT

DETAILS OF TURBINE INSPECTION PORT & LOC (15)

TURBINE INSPECTION PORT

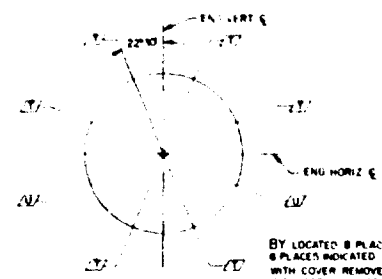

BY LOCATED 8 PLACES
8 PLACES INDICATED BY Δ
WITH COVER REMOVED
2 PLACES INDICATED BY ∇
WITH IGNITER REMOVED

MAIN BURNER INSPECTION PORT
SCHEMATIC VIEW LOOKING FORWARD
8 PORTS EQUALLY SPACED
SCALE: NINE

C

Best Available Copy

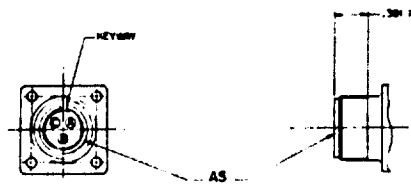

THIS CONNECTOR ACCOMMODATES ANY CONNECTOR THAT MATES WITH MS 3402-108L-3P
AERODYNAMIC BRAKE POSITION TRANSDUCER
 SCHEMATIC OF PIN DESIGNATION

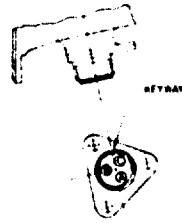
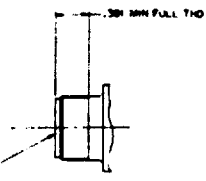

THIS CONNECTOR ACCOMMODATES ANY CONNECTOR THAT MATES WITH MS 3402-145-7PW-1901
LOW MOTOR SPEED TRANSDUCER BT

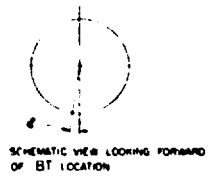

SCHEMATIC VIEW LOOKING FORWARD OF BT LOCATION

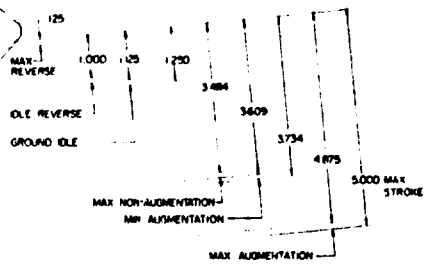

POWER ROD AJ
 MAX PUSH-PULL 1000 LB (AGAINST STOP)
 CONFIGURATION OF ATTACHMENTS, DIRECTION OF POWER STROKE TO BE COORDINATED

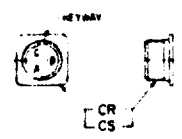

THIS CONNECTOR ACCOMMODATES ANY CONNECTOR THAT MATES WITH MS 3402-145-7PW-1901
SECONDARY AIR VALVE POSITION INDICATOR SWITCH
 SCHEMATIC OF PIN DESIGNATION

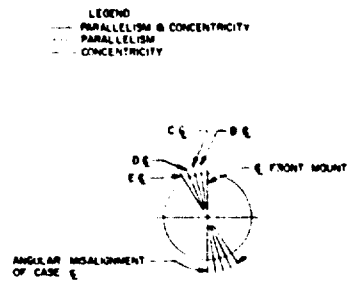
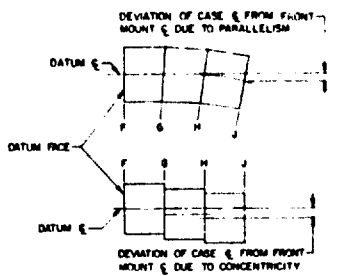
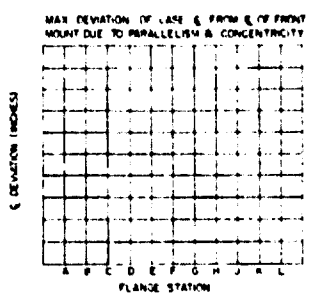
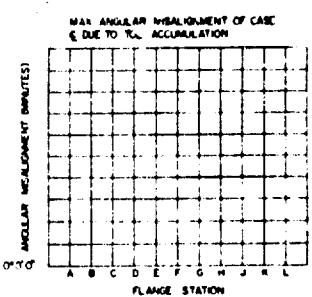

MAX ALLOWABLE LOADS FOR AIR BLEED PORTS

- T - TORQUE APPLIED TO BLEED PORT FLG
- M - BENDING MOMENT APPLIED AT FLG - 1/2 IN
- M2 - CIRCUMFERENTIAL MOMENT APPLIED AT FLG - 1/2 IN
- V1, V2 - APPLIED SHEAR LOADS AT BLEED PORT FLG IN OPPOSITE VERTICAL DIRECTIONS RESPECTIVELY
- P - APPLIED TENSION LOAD

(THESE ARE TO BE USED AS POSITIVE VALUES)

LOADS

M1 - 100
 M2 - 100
 V1 - 100
 V2 - 100
 P - 100
 T - 100

LOADS

M1 - 100
 M2 - 100
 V1 - 100
 V2 - 100
 P - 100
 T - 100

CIRCUIT AIR BLEED PORT

ANTI ICE AIR BLEED PORT

DES BY [initials]
 ED BY [initials]
 REV BY [initials]
 REMOVED

Best Available Copy

D

Pratt & Whitney Aircraft
Specification No. 2710

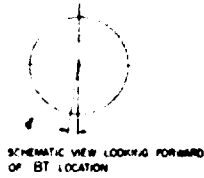

NOT ACCOMMODATED FOR THIS MATTER (2-MS-778180)

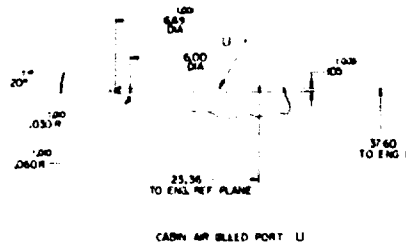
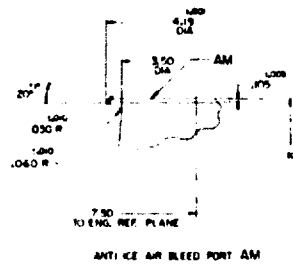

MAX. ALLOWABLE LOADS IN AIR BLEED PORTS
 1. FORCE APPLIED TO BLEED PORT FLO
 2. AXIAL MOMENT APPLIED AT FLO
 3. TORQUE APPLIED AT FLO
 4. SHEAR APPLIED AT FLO
 5. BENDING MOMENT APPLIED AT FLO
 6. AXIAL & VERT. DIMENSIONS RESPECTIVELY
 7. APPLIED TENSILE LOADS
 DIMENSIONS ARE TO BE USED AS INDICATED UNLESS

LOADS

- M 1.1 K
- M2 1.1 K
- M3 1.1 K
- P 1.1 K
- T 1.1 K

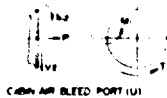

LOADS

- M 1.1 K
- M2 1.1 K
- M3 1.1 K
- P 1.1 K
- T 1.1 K



- 1. SPACE AVAILABLE FOR ACCESSORIES
- 2. ACCESSORY CLEARANCES LESS THAN 25 MUST BE COORDINATED WITH PRWA
- 3. DIMENSIONS SPACE FOR REMOVAL
- 4. DIMENSIONS DETAILS TO BE COORDINATED
- 5. DIMENSIONS FOR TRUE POS OF FEATURE* SHOWN
- 6. ARE CENTERLINES OF CASE CONTAINING SUCH FEATURES UNLESS OTHERWISE SHOWN
- 7. ALL DIM. SHOWN ARE NOM UNLESS OTHERWISE SHOWN

2129601
SHEET 1

AUG 8, 1964

2129601
PART 1

PRELIMINARY
SUBJECT
TO CHANGE

PRATT & WHITNEY AIRCRAFT
CONTROLLED

NOTES FOR INSTALLATION ON
 BOMB ENGINE INSTALLATION
 SHEET 1 LH SIDE VIEW
 SHEET 2 RH SIDE VIEW
 SHEET 3 ADDITIONAL INFORMATION
 SHEET 4 PLUMBING & WIRING

NOTICE TO ALL PERSONS RECEIVING THIS DRAWING
 THIS DRAWING IS THE PROPERTY OF PRATT & WHITNEY AIRCRAFT COMPANY AND IS LOANED TO YOU FOR YOUR INFORMATION ONLY. IT IS NOT TO BE REPRODUCED OR TRANSMITTED IN ANY FORM OR BY ANY MEANS, ELECTRONIC OR MECHANICAL, INCLUDING PHOTOCOPYING, RECORDING, OR BY ANY INFORMATION STORAGE AND RETRIEVAL SYSTEM, WITHOUT THE WRITTEN PERMISSION OF PRATT & WHITNEY AIRCRAFT COMPANY.

DATE	BY	DESIGNED BY	CHECKED BY
11/2/64			
ENGINE INSTALLATION (JTF17A21R PRODUCTION)			
PRATT & WHITNEY AIRCRAFT COMPANY 7A-55-66-8	FORM 2000-10 77845	REV	2129601
ISSUED BY	DATE	APPROVED BY	CONTROL NO.
			(SHEET 3 OF 4)

E

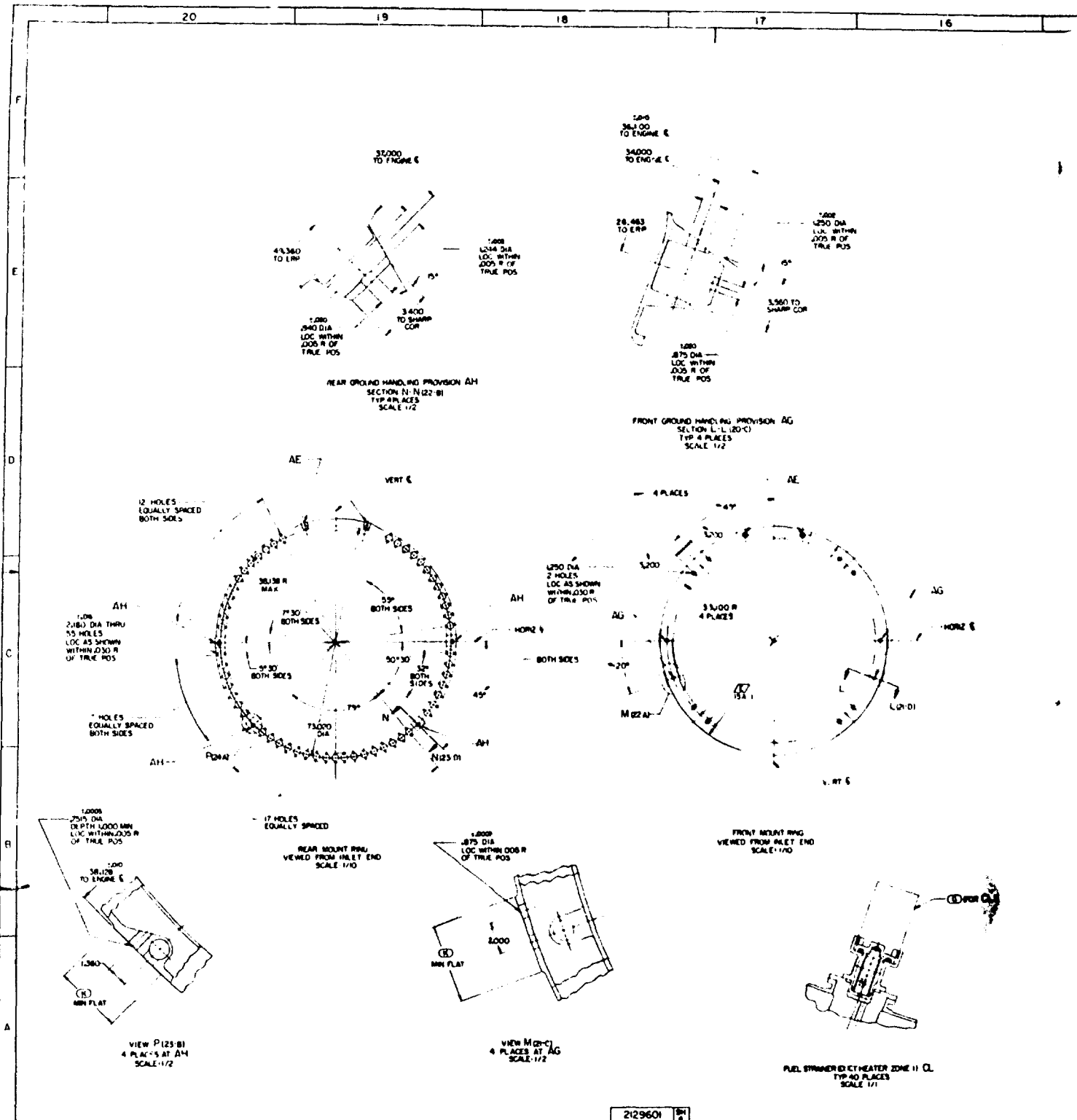

Best Available Copy

A

15 14 13 12 11

(SPACE PROVIDED FOR
VIBRATION PICKUP (K))

1004
2000A
1000000
AND MORE

FOR INLET BELT
REMOVAL



SECTION J (UPPER)
TYP. 8 PLACES
SCALE: 1:2

VIEW FROM
TOP & PLACES
SCALE: 1:2

1004
2000A
1000000
AND MORE

LIMIT LOADS FOR INLET FLANGE A

P: RADIAL LOAD: 50000 LBS
 V: VERTICAL SHEAR LOAD: 20000 LBS
 M: HORIZONTAL SHEAR LOAD: 15000 LBS
 M: TORQUE BENDING MOMENT: 2500000 IN. LBS
 M: VERTICAL BENDING MOMENT: 1250000 IN. LBS

THESE LOADS REPRESENT THE LIMIT LOADS
 TO BE DISTRIBUTED TO FLANGE A ATTACHMENTS
 AND DO NOT OCCUR SIMULTANEOUSLY

Best Available Copy

B

ALL DIMENSIONS IN INCHES UNLESS OTHERWISE SPECIFIED

11 10 9 8 7 6

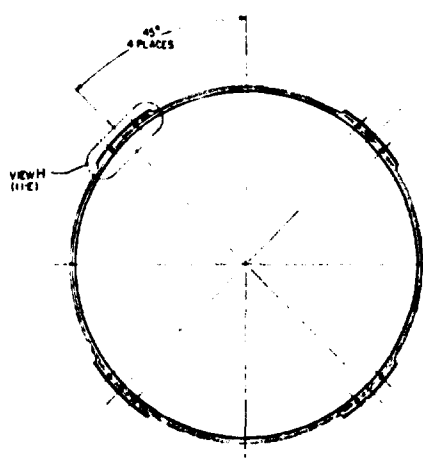
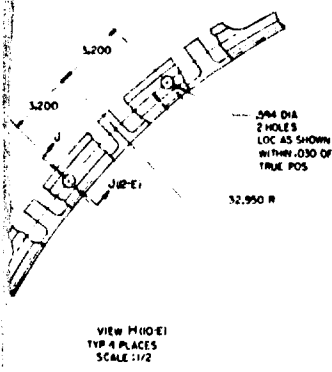

FLANGE A
VIEWED FROM INLET END

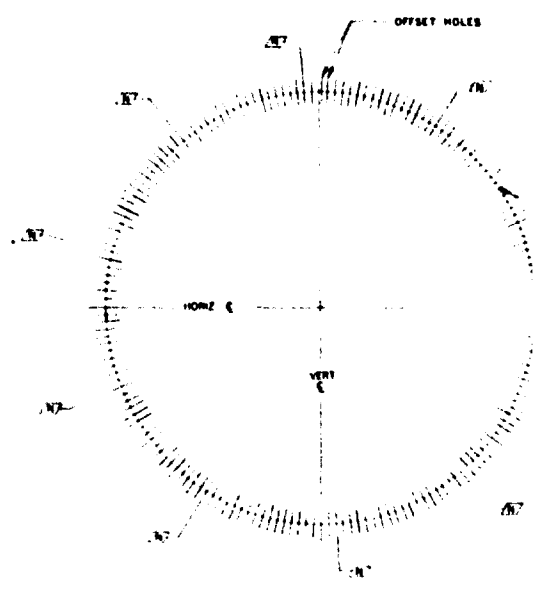

FLANGE C
VIEWED FROM INLET END

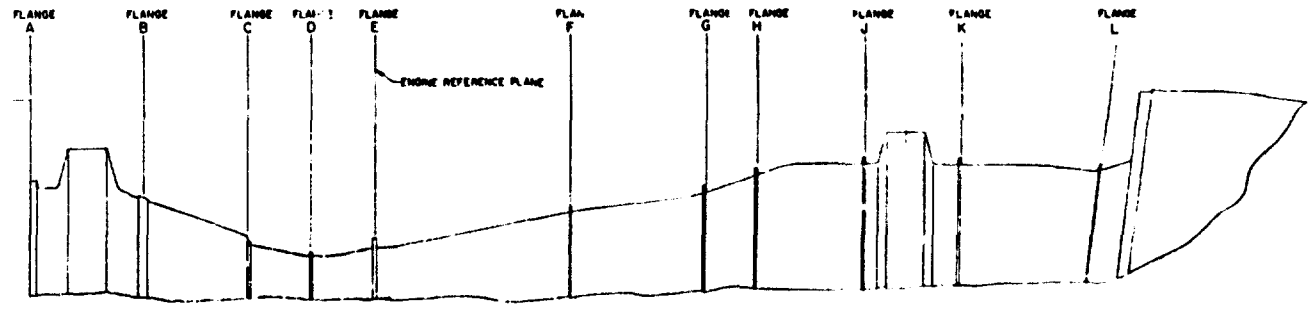
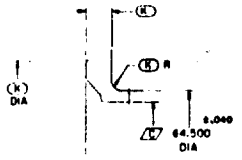

2129601
Best Available Copy

C

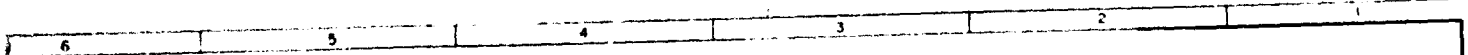

OFFSET HOLES

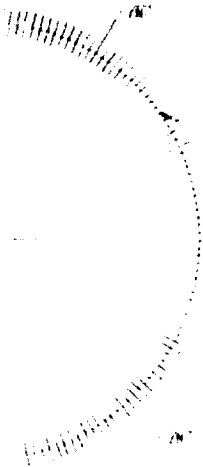

BF
(SPACE PROVIDED FOR VIBRATION PICK-UP (K.))

1/8" DIA
180 HOLES
180 HOLES EQUALLY SPACED IN
2 HOLES OFFSET AS SHOWN
10 HOLES OMITTED AT LOC
INDICATED BY $\sqrt{2}$
ALL LOC WITHIN 1/8" OF
TRUE POS

2129601
Sheet 4

AUG 8, 1966

2129601
SHEET 4

PRELIMINARY
SUBJECT
TO CHANGE

PRATT & WHITNEY AIRCRAFT
CONTROLLED

- ① INDICATES DETAILS TO BE COORDINATED WHEN IT IS DECIDED THAT PWMA WILL NOT SUPPLY THE PARTS (BUT INSTRUCTIONS MUST BE MADE FOR THE CUSTOMER TO ATTACH INSTITUTE STANDARD, ONE OF THE FOLLOWING ALTERNATIVES MAY BE USED):
 - (A) 1/8" DIA BRACKET, CONSISTING OF A SQUARE ADAPTER TO WHICH THE CUSTOMER MAY ATTACH HIS BRKT (OTHER ENG. PARTS MAY BE PROVIDED, SUCH AS STUDS TO WHICH THE CUSTOMER PART MAY BE ASSEMBLED) (PROVISIONS MAY BE MADE IN EXISTING PWMA BRKTS TO FACILITATE THE CUSTOMER TO ATTACH HIS PART)
 - (B) WHEN THE CUSTOMER PART REQUIREMENTS ARE RECEIVED PWMA WILL PREPARE A FIELD SURVEY SHOWING ALL THE BRKTS, WITH APPROVED THE INSTALLATION DRG. IN 1:1 SHOW ALL THE BRKTS PROVIDED FOR CUSTOMER USE, INCLUDING DIMENSIONING OF PERTINENT FEATURES SUCH AS HOLE LOCATIONS, SIZES, THREADS, CALLOUTS, ALLOWABLE LOAD AT CLAMPING PROVISION, ETC. PWMA DOES NOT PERMIT THE CUSTOMER TO REMOVE OR LOOSEN ENG BOLTS IN ORDER TO INSTALL BRKTS OR OTHER HARDWARE PARTS. THE ENG. PART WILL BE PROVIDED EITHER WITH THE ENTIRE BRKT ASSEMBLY OR WITH BRKT/ENG ASSY WITH ATTACHING PARTS WITHOUT DISTURBING THE BOLTED ENG ASSY.
 - (C) ALL DIM. SHOWN ARE NOMINAL UNLESS OTHERWISE SHOWN
 - (D) ATTACHMENT FOR INSTALLATION BRKTS
 - (E) DIMENSIONS FOR TRUE POS OF FEATURES SHOWN ARE CENTERLINES OF CASE CONTAINING SUCH FEATURES UNLESS OTHERWISE SHOWN
 - (F) ASSEMBLE THESE BRKTS WITH BEAD TOWARD REAR OF END
 - (G) THESE BRKTS ASSEMBLED ON REAR OF FLANGE

FOR ENGINE INSTALLATION DRG
DESIGN ENGINE INSTALLATION
SHEET 1 IN 574-110
SHEET 2 ON SIDE VIEW
SHEET 3 ADDITIONAL INFO
SHEET 4 FLANGE & BOLTS

NOTICE TO ALL PERSONS EXAMINING THIS DRAWING
THIS DRAWING IS THE PROPERTY OF PRATT & WHITNEY AIRCRAFT COMPANY. IT IS TO BE USED ONLY FOR THE PURPOSES SPECIFIED THEREIN. IT IS NOT TO BE REPRODUCED, COPIED, OR TRANSMITTED IN ANY FORM OR BY ANY MEANS, ELECTRONIC OR MECHANICAL, INCLUDING PHOTOCOPYING, RECORDING, OR BY ANY INFORMATION STORAGE AND RETRIEVAL SYSTEM, WITHOUT THE WRITTEN PERMISSION OF PRATT & WHITNEY AIRCRAFT COMPANY.

DATE	BY	APPROVED	CONTROLLED
17-8-66	J.P.A.		
ENGINE INSTALLATION (JTF17A-210 PRODUCTION)			
DATE SHIP ON	NO.	2129601	
7A-85-66-0	7745		
PREPARED UNDER CONTRACT	SCALE	SHEET 4 OF 4	

Best Available Copy

D

FLIGHT FRONT MOUNT DATA
 SCHEMATIC REAR VIEW OF FRONT MOUNT
 DIRECTION OF LOADS POSITIVE AS SHOWN, NEGATIVE IN OPPOSITE DIRECTION

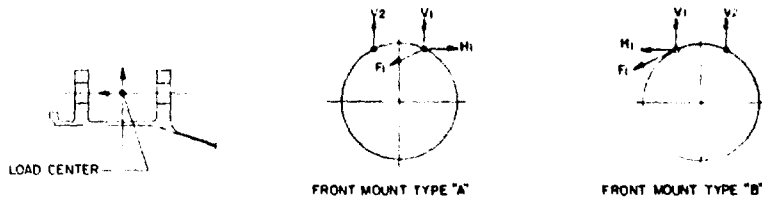

DEFINITIONS FOR EACH MOUNT TYPE:
 F1=AXIAL LOAD ACTING AS SHOWN ON FRONT MOUNT ATTACHMENT
 H1=HORIZONTAL LOAD ACTING AS SHOWN ON FRONT MOUNT ATTACHMENT
 V1,V2=VERTICAL LOAD ACTING AS SHOWN ON FRONT MOUNT ATTACHMENT

LOADS BASED ON THE FOLLOWING CONDITIONS:
 1. LOADS (H1, F1, V1, V2) ACTING ON FRONT MOUNT MUST BE APPLIED UNIFORMLY ON SURFACES AS SHOWN WITH LOAD CENTER LOCATED AT A RADIAL DISTANCE FROM ENGINE ϕ OF 34.328+0.050 R

THE ALLOWABLE LIMIT LOADS FOR EACH FRONT MOUNT ATTACHMENT SATISFY ALL VALUES GIVEN BELOW. THESE LOADS REPRESENT THE MAXIMUM LOADS AT EACH LOCATION AND DO NOT OCCUR SIMULTANEOUSLY

1. V1 91,000 LBS 2. V2 114,000 LBS 3. H1 41,000 4. F1 1122,000 LBS

SHIPPING & GROUND HANDLING FRONT MOUNT DATA
 SCHEMATIC REAR VIEW OF FRONT MOUNT WITH DIRECTION OF LOADS POSITIVE AS SHOWN
 NEGATIVE IN OPPOSITE DIRECTION. AXIAL LOADS ARE POSITIVE TO REAR

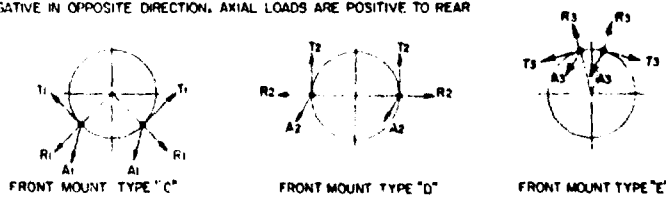

DEFINITIONS FOR EACH MOUNT TYPE:
 R1, R2=RADIAL LOAD ACTING ON FRONT MOUNT GROUND HANDLING ATTACHMENT
 T1, T2=TANGENTIAL LOAD ACTING ON FRONT MOUNT GROUND HANDLING ATTACHMENT
 A1, A2=AXIAL LOAD ACTING ON FRONT MOUNT GROUND HANDLING ATTACHMENT WITH NO OVERTURNING MOMENT
 R3=RADIAL GROUND HANDLING & SHIPPING LOAD ACTING ON EITHER FRONT FLIGHT ATTACHMENT
 T3=TANGENTIAL GROUND HANDLING & SHIPPING LOAD ACTING ON EITHER FRONT FLIGHT ATTACHMENT
 A3=AXIAL GROUND HANDLING & SHIPPING LOAD ACTING ON EITHER FRONT FLIGHT ATTACHMENT APPLIED WITH NO OVERTURNING MOMENT

THE GROUND HANDLING & SHIPPING ALLOWABLE LIMIT LOADS FOR FRONT MOUNT ATTACHMENT MUST SATISFY ALL VALUES GIVEN BELOW. THESE LOADS REPRESENT THE MAXIMUM LOADS AT EACH LOCATION AND DO NOT OCCUR SIMULTANEOUSLY

1. R1 1 (K) 4. R2 1 (K) 7. R3 1 (K)
 2. T1 1 (K) 5. T2 1 (K) 8. T3 1 (K)
 3. A1 1 (K) 6. A2 1 (K) 9. A3 1 (K)

FLIGHT REAR MOUNT DATA
 SCHEMATIC REAR VIEW OF REAR MOUNT
 DIRECTION OF LOADS POSITIVE AS SHOWN, NEGATIVE IN OPPOSITE DIRECTION



DEFINITIONS FOR EACH MOUNT TYPE:
 LINKAGES (SUPPLIED BY CUSTOMER) TO HAVE ATTACHMENT MUST HAVE ADEQUATE ALLOWANCE FOR AS SHOWN ON INSTALLATION DRAWING
 A1=AXIAL LOAD ACTING AS SHOWN ON REAR MOUNT ATTACHMENT APPLIED AT ϕ OF HOLE AT ENGINE MOUNT
 H2=TANGENTIAL LOAD ACTING ON REAR MOUNT ATTACHMENT
 V2=VERTICAL LOAD ACTING ON REAR MOUNT ATTACHMENT

THE ALLOWABLE LIMIT LOADS FOR REAR MOUNT ATTACHMENT MUST SATISFY ALL VALUES GIVEN BELOW. THESE LOADS REPRESENT THE MAXIMUM LOADS AT EACH LOCATION AND DO NOT OCCUR SIMULTANEOUSLY

1. V2 66,500 LBS 2. H2 1122,500 LBS

SHIPPING & GROUND HANDLING REAR MOUNT DATA
 SCHEMATIC REAR VIEW OF REAR MOUNT WITH DIRECTION OF LOADS POSITIVE AS SHOWN
 NEGATIVE IN OPPOSITE DIRECTION. AXIAL LOADS ARE POSITIVE TO REAR

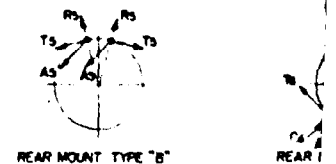

DEFINITIONS FOR EACH MOUNT TYPE:
 A1=AXIAL LOAD ACTING ON EITHER REAR MOUNT ATTACHMENT
 T1=TANGENTIAL LOAD ACTING ON EITHER REAR MOUNT ATTACHMENT
 R1=AXIAL GROUND HANDLING & SHIPPING LOAD ACTING AT ϕ OF HOLE WITH (TO BE TAKEN BY SINGLE FLANGE)
 T2=TANGENTIAL GROUND HANDLING & SHIPPING FLIGHT ATTACHMENT (BOTH FLANGES)
 R3=RADIAL GROUND HANDLING & SHIPPING FLIGHT ATTACHMENT (BOTH FLANGES)
 T3=TANGENTIAL GROUND HANDLING & SHIPPING FLIGHT ATTACHMENT (BOTH FLANGES)

THE GROUND HANDLING & SHIPPING ALLOWABLE LIMIT LOADS FOR REAR MOUNT ATTACHMENT MUST SATISFY ALL EQUATIONS REPRESENT THE MAXIMUM LOADS AT EACH LOCATION AND DO NOT OCCUR SIMULTANEOUSLY

1. A1 1 (K) 4. A2 1 (K)
 2. T1 1 (K) 5. T2 1 (K)
 3. R1 1 (K) 6. R2 1 (K)

STANDARD AIRCRAFT DATA
 PART NUMBER - ENGINE TYPE - 1171
 LAYOUT
 REV. DATE 01

(K) VALUES TO BE COORDINATED

Best Available Copy

A

FLIGHT REAR MOUNT DATA
SCHEMATIC REAR VIEW OF REAR MOUNT
DIRECTION OF LOADS POSITIVE AS SHOWN, NEGATIVE IN OPPOSITE DIRECTION



DEFINITIONS FOR EACH MOUNT TYPE:
LINKAGES (SUPPLIED BY CUSTOMER) TO HAVE ATTACHMENT LOCATED AT R1 (K)
LINKAGE MUST HAVE ADEQUATE ALLOWANCE FOR ENGINE THERMAL EXPANSIONS
AS SHOWN ON INSTALLATION DRAWING

- A4=AXIAL LOAD ACTING AS SHOWN ON REAR MOUNT ATTACHMENT
APPLIED AT C OF MOUNT HOLE AT ENGINE MOUNT RING
- H2=TANGENTIAL LOAD ACTING ON REAR MOUNT LINKAGE ATTACHMENT
- V2=VERTICAL LOAD ACTING ON REAR MOUNT LINKAGE ATTACHMENT

THE ALLOWABLE LIMIT LOADS FOR REAR MOUNT ATTACHMENT MUST SATISFY
ALL VALUES GIVEN BELOW THESE LOADS REPRESENT THE MAXIMUM
LOADS AT EACH LOCATION AND DO NOT OCCUR SIMULTANEOUSLY

1.V2 6,500 LBS 2.H2 122,500 LBS 3.A4 12 (K)

SHIPPING & GROUND HANDLING REAR MOUNT DATA
SCHEMATIC REAR VIEW OF REAR MOUNT WITH DIRECTION OF LOADS POSITIVE AS SHOWN
NEGATIVE IN OPPOSITE DIRECTION AXIAL LOADS ARE POSITIVE TO THE REAR



DEFINITIONS FOR EACH MOUNT TYPE:
A1=AXIAL LOAD ACTING ON EITHER REAR MOUNT GROUND HANDLING
T1=TANGENTIAL LOAD ACTING ON EITHER REAR MOUNT GROUND HANDLING ATTACHMENT
R1=AXIAL LOAD ACTING ON EITHER REAR MOUNT GROUND HANDLING ATTACHMENT
A2=AXIAL GROUND HANDLING & SHIPPING LOAD ACTING ON EITHER REAR FLIGHT
ATTACHMENT APPLIED AT C OF HOLE WITH NO OVERTURNING MOMENT (LOAD
TO BE TAKEN BY SINGLE FLANGE)
T2=TANGENTIAL GROUND HANDLING & SHIPPING LOAD ACTING ON EITHER REAR
FLIGHT ATTACHMENT (BOTH FLANGES)
R2=AXIAL GROUND HANDLING & SHIPPING LOAD ACTING ON EITHER REAR
FLIGHT ATTACHMENT (BOTH FLANGES)

THE GROUND HANDLING & SHIPPING ALLOWABLE LIMIT LOADS FOR REAR MOUNT
ATTACHMENT MUST SATISFY ALL EQUATIONS GIVEN BELOW THESE LOADS
REPRESENT THE MAXIMUM LOADS AT EACH LOCATION AND DO NOT OCCUR
SIMULTANEOUSLY

- 1.A1 13 (K) 4.A2 13 (K) 7.A3 13 (K)
- 2.T1 3 (K) 5.T2 13 (K) 8.T3 13 (K)
- 3.R1 3 (K) 6.R2 13 (K) 9.R3 13 (K)

(K) VALUES TO BE COORDINATED

2128091

AUGUST 8, 1966

2128091

PRELIMINARY
SUBJECT
TO CHANGE
PRATT & WHITNEY AIRCRAFT
CONTROLLED

NOTICE TO ALL PERSONS RECEIVING THIS DRAWING
THIS DRAWING IS ONLY A PRELIMINARY DRAWING AND DOES NOT REPRESENT THE FINAL DESIGN OF
PRATT & WHITNEY AIRCRAFT. THE DESIGNER'S OFFICE SHALL BE RESPONSIBLE FOR THE DESIGN OF
THIS DRAWING AND SHALL BE RESPONSIBLE FOR THE DESIGN OF THIS DRAWING. THE DESIGNER'S
OFFICE SHALL BE RESPONSIBLE FOR THE DESIGN OF THIS DRAWING. THE DESIGNER'S OFFICE
SHALL BE RESPONSIBLE FOR THE DESIGN OF THIS DRAWING.

DESIGN	PRATT & WHITNEY AIRCRAFT	DESIGNER'S OFFICE	PRATT & WHITNEY AIRCRAFT CORPORATION
DATE	8/11/66	DESIGNER'S NAME	A
APPROVED	7/1/66	DESIGNER'S SIGNATURE	
PREPARED UNDER CONTRACT	FA-55-66-8	CODE SHEET NO.	77445
PERFORMED UNDER CONTRACT		REV.	F
		SCALE	1:1
		APPROVED BY	LD (SHELF)
			2128091

Best Available Copy

3

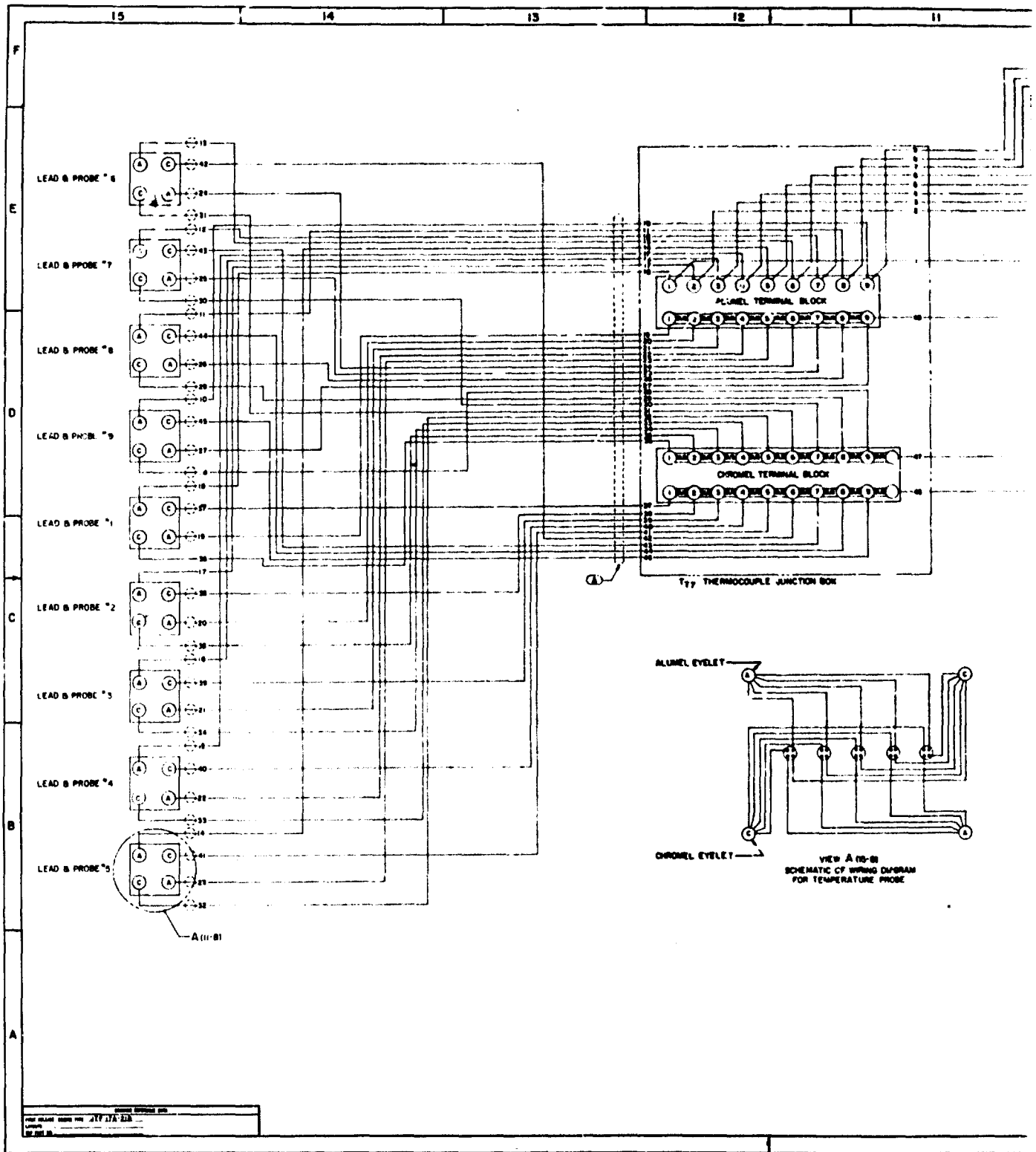

A

Best Available Copy

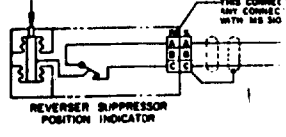
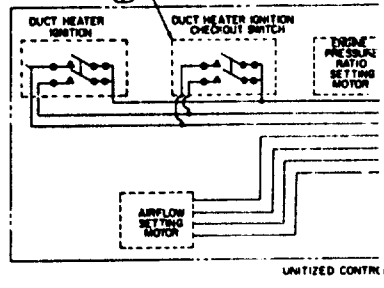
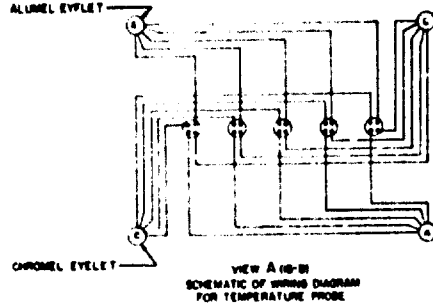
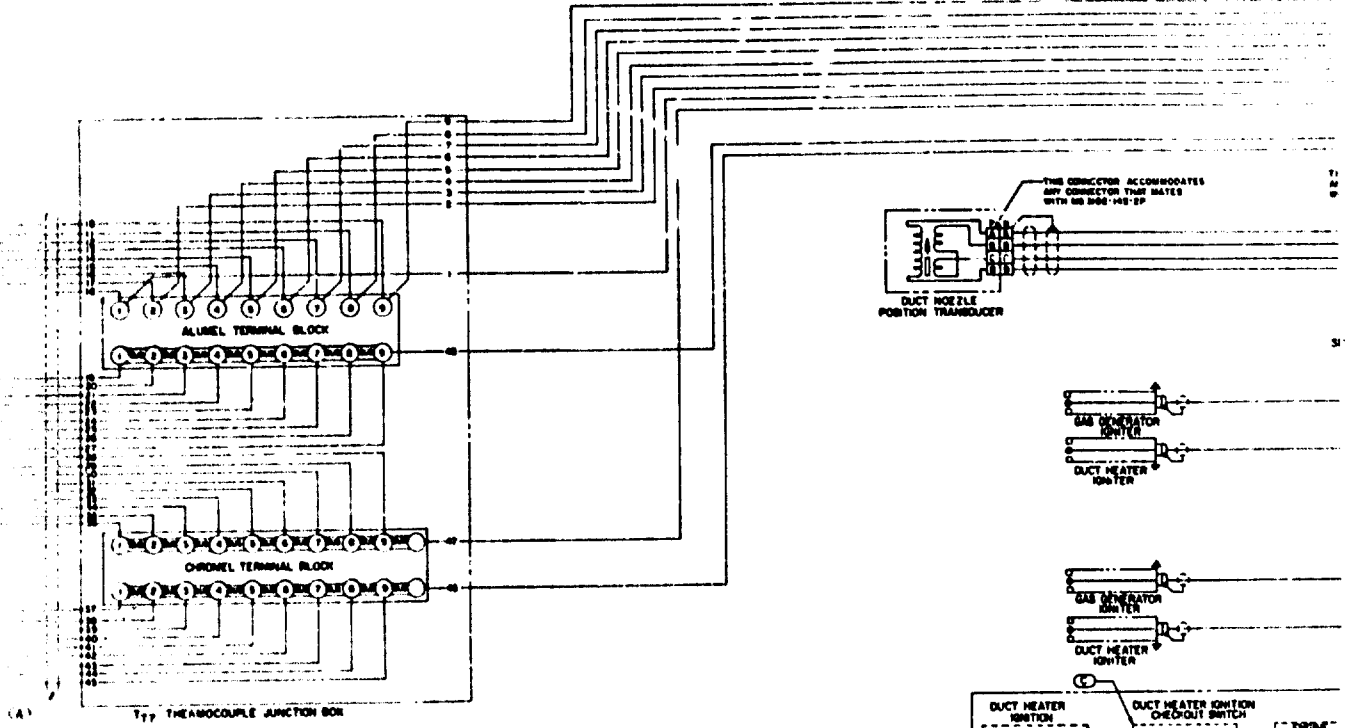

Best Available Copy

3

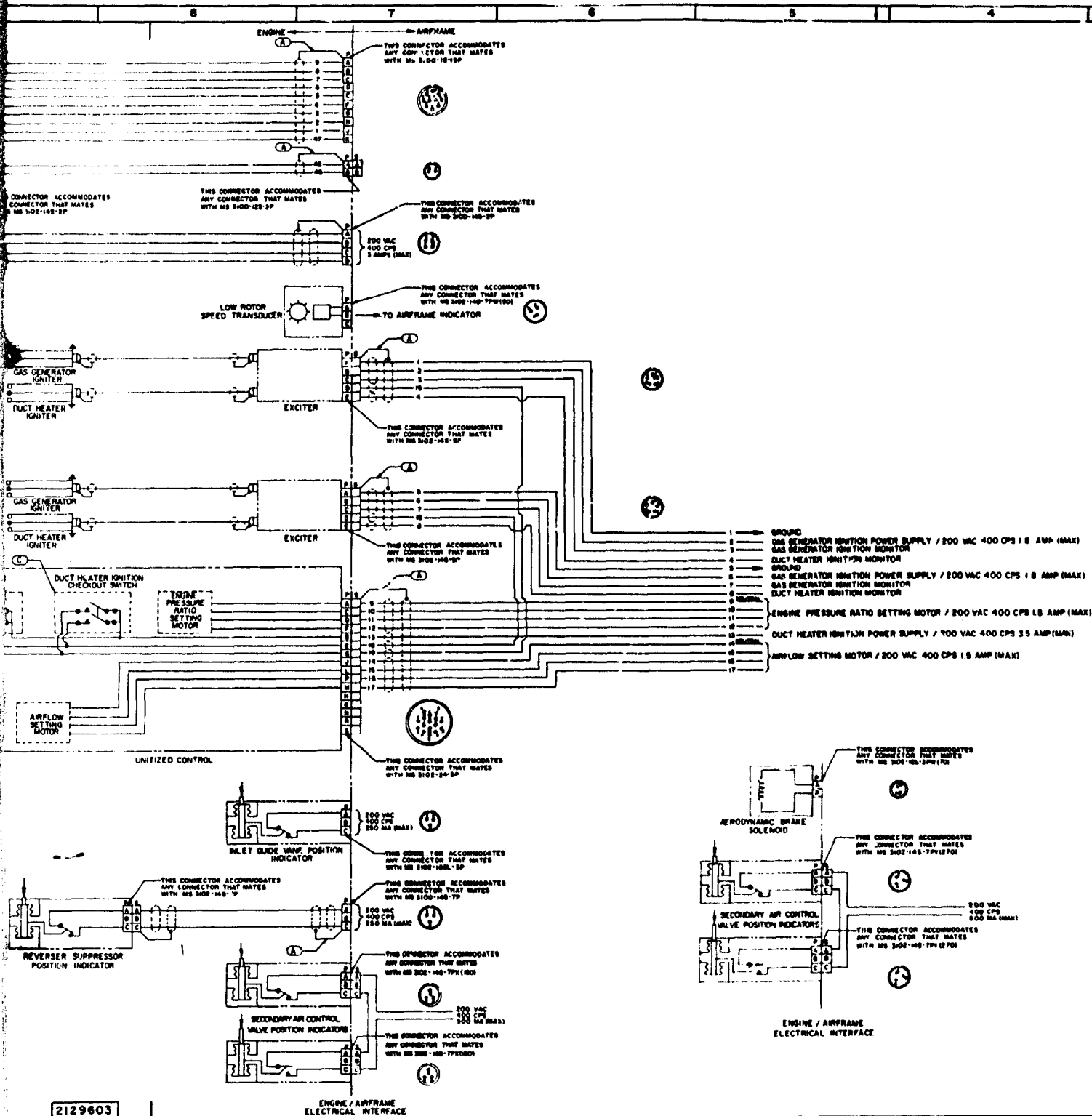

Best Available Copy

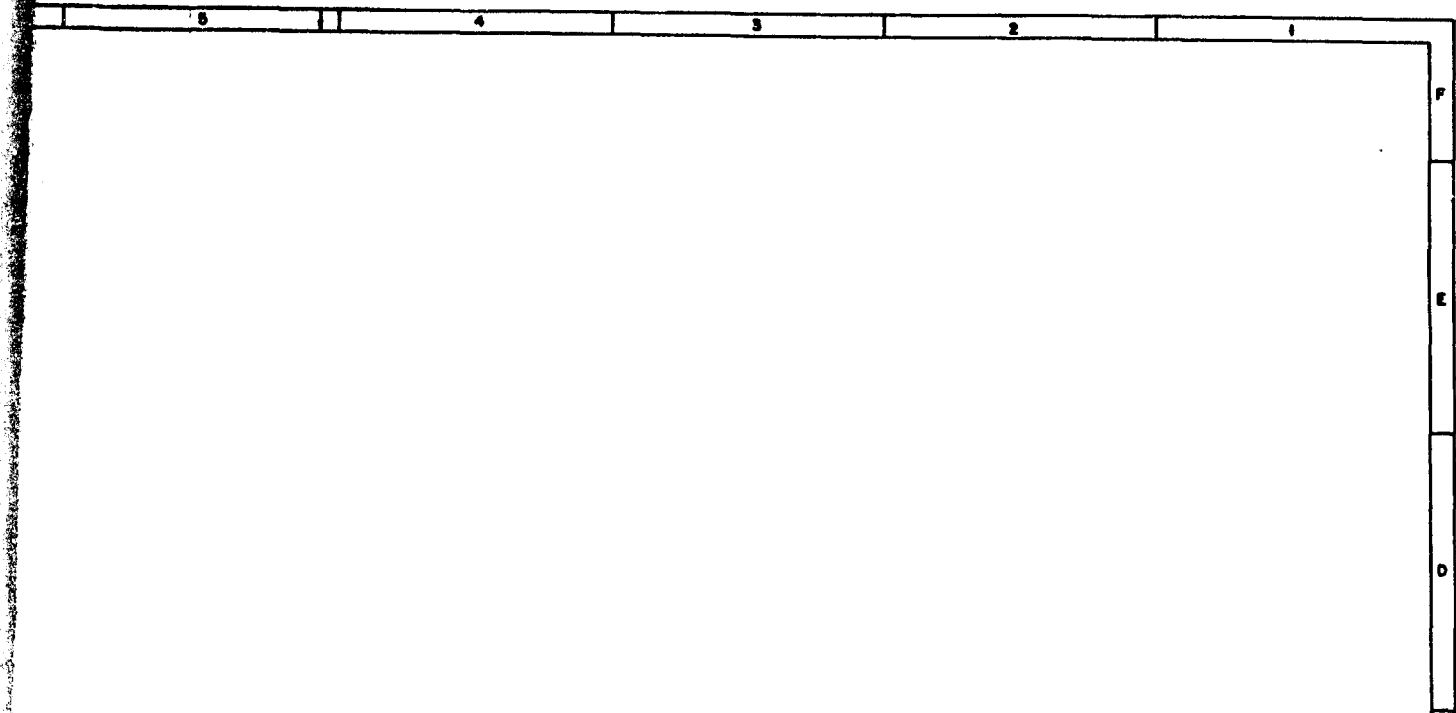

- 1 GROUND
- 2 GAS GENERATOR IGNITION POWER SUPPLY / 200 VAC 400 CPS 1.8 AMP (MAX)
- 3 GAS GENERATOR IGNITION MONITOR
- 4 DUCT HEATER IGNITION MONITOR
- 5 GROUND
- 6 GAS GENERATOR IGNITION POWER SUPPLY / 200 VAC 400 CPS 1.8 AMP (MAX)
- 7 GAS GENERATOR IGNITION MONITOR
- 8 DUCT HEATER IGNITION MONITOR
- 9 GROUND
- 10 ENGINE PRESSURE RATIO SETTING MOTOR / 200 VAC 400 CPS 1.8 AMP (MAX)
- 11 GROUND
- 12 DUCT HEATER IGNITION POWER SUPPLY / 200 VAC 400 CPS 3.8 AMP (MAX)
- 13 GROUND
- 14 AIRFLOW SETTING MOTOR / 200 VAC 400 CPS 1.8 AMP (MAX)
- 15 GROUND
- 16
- 17

2129603

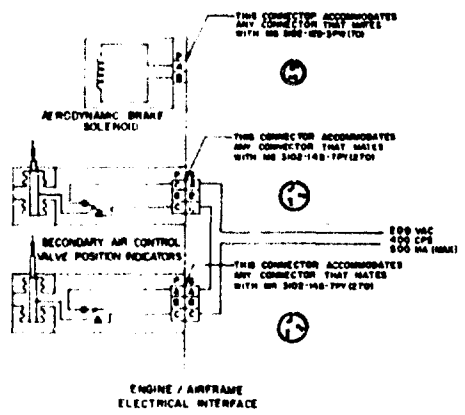

2129603

AUGUST 8, 1966

PRELIMINARY
SUBJECT
TO CHANGE

PRATT & WHITNEY AIRCRAFT
CONTROLLED

NOTICE TO ALL PERSONS RECEIVING THIS DRAWING
THIS DRAWING IS THE PROPERTY OF PRATT & WHITNEY AIRCRAFT COMPANY AND IS LOANED TO YOU FOR YOUR INFORMATION ONLY. IT IS NOT TO BE REPRODUCED OR TRANSMITTED IN ANY FORM OR BY ANY MEANS, ELECTRONIC OR MECHANICAL, INCLUDING PHOTOCOPYING, RECORDING, OR BY ANY INFORMATION STORAGE AND RETRIEVAL SYSTEM, WITHOUT THE WRITTEN PERMISSION OF PRATT & WHITNEY AIRCRAFT COMPANY.

DATE	REVISED	BY	APPROVED
12/15/66		J	
DIAGRAM		ELECTRICAL INSTALLATION	
TITLE		MILITARY AIRCRAFT	
PRATT & WHITNEY AIRCRAFT COMPANY		77445	
PUBLISHED BY		2129603	

- ⊖ SWITCH IS IN CLOSED POSITION WHEN POWER LEVER HANDLE IS AT OR NEAR IDLE
- ⊕ TO BE COORDINATED
- ⊖ METALLIC BRAD FOR INSULATION PROTECTION

D

APPENDIX A

1.0 SCOPE

1.1 Scope - This appendix establishes the requirements for the Flight Test Status (FTS) engines to be delivered under Phase III of the Supersonic Transport Program. The engines will be in general accordance with the requirements of Model Specification No. 2710 except as modified in this appendix.

3.1.1 Dimension and Installation Drawing - Change the Engine Installation Drawing No. to 2130301.

Add the following paragraph:

"3.2.2 Dry Weight of Engine - The dry weight of the FTS engine shall be within 3.0% of the total dry weight specified in 3.2."

6.1 Performance Ratings - Add the following sentences: "The specified engine thrusts and thrust specific fuel consumptions (TSFC) for the FTS engine shall be as specified in table I and table II within 3% and 5%, respectively. If the thrust is less than the production rating, provisions shall be made for limited time operation at production thrust levels to accomplish Phase III airplane performance demonstration."

24.0 ENGINE NOISE LEVELS - Add the following sentence: "The specified noise values shall be objectives for the Phase III program."

28.0 ENGINE TYPE CERTIFICATION TEST - Replace 28.0 with the following paragraphs:

28.0 "ENGINE FLIGHT TEST STATUS - Engine Flight Test Status shall be accomplished by satisfactory completion of sea level and altitude tests in accordance with 28.2.2.2.2.1 through 28.2.2.2.4.

28.1 Test Approval - The engine shall be considered to have satisfactorily completed these tests if, at the completion of the engine recalibration specified in 28.2.2.2.3.1 it is within the specified limits and the engine is still in operational condition as substantiated by conducting a final acceptance test run in accordance with the schedule specified in 29.0.

28.1.1 Reports

28.1.1.1 Test Reports - Following completion of each separate engine or component test, or consecutive group of tests conducted on any single test assembly or components, a report shall be submitted.

28.1.1.1.1 Preparation - These reports shall contain essentially the following items:

- a. Cover (Title of report, number of the report, source of report, date, name(s) of the author(s) and contract number).
- b. Title page (Title of report, number of the report, source of the report, date, name(s) of the author(s), and contract number).
- c. Abstract (A brief statement of the contents of the report, including the objective).
- d. Table of contents.
- e. List of illustrations (Provide figure numbers and captions of all illustrations. Photographs, charts, and graphs should be treated as illustrations and given figure numbers. When used in a separate series, tables should be given Roman numerals. Examples: figure 1, figure 2, etc.; table I, table II, etc..)
- f. Summary (A brief resume of the test conducted including objectives, procedures, results, conclusions, and recommendations).
- g. Body of the report.
 1. Brief general description of the engine or of the component(s) and a detailed description of all features which differ from the previous model, if applicable.
 2. If approval is being requested, without test, based on similarity to a component or assembly for which previous test approval was obtained, any physical or functional dissimilarities or differences in testing requirements with respect to the test component and reference to the approved component test report shall be included.
 3. Method of test (general description of test facility, equipment and methods used in conducting the test).
 4. Record of test (chronological history of all events in connection with all of the testing).
 5. Analysis of results (a complete discussion of all phases of the test, such as probable reasons for failure and unusual wear, comparison in performance with previous models, and analysis of general operation).
 6. Calibration and recalibration data including acceptance limits (data in both uncorrected and corrected form, if applicable, shall be shown by suitable curves).
 7. Tabulated data of all pertinent instrument readings and all required instrument readings taken during the test. Extraneous readings, which P&WA may desire to take during the test, need not be reported.
 8. Description of the condition of the engine or components at disassembly inspection.
 9. Conclusions and recommendations.

28.1.1.1.2 Number and Distribution of Copies - Five copies of the report shall be forwarded to the Federal Aviation Agency.

28.2 Quality Assurance Provisions

28.2.1 General - Turbofan aircraft engines, components, and test apparatus shall be subject to inspection by authorized Government representatives who shall be given all reasonable facilities to determine conformance with this specification. All instructions for testing of the engine shall be available to the Government representative.

28.2.1.1 Accuracy of Data - Automatic recording equipment and associated test apparatus required to evaluate engine variables versus time shall have a static accuracy within 2% of the values obtained at the maximum rating of the engine. The accuracy of transient data and the corresponding instrument calibration methods shall be subject to review by the authorized Government representative and shall be described in the Flight Test Status report. All instruments and equipment shall be calibrated as necessary to insure that the required degree of accuracy is maintained.

28.2.2 Engine Tests

28.2.2.1 Test Conditions - The following conditions shall apply for all engine tests unless otherwise specified.

28.2.2.1.1 Test Apparatus

28.2.2.1.1.1 Automatic Recording Equipment - Automatic continuous recording equipment shall be used to record data during the execution of that part of the engine tests (see 28.2.2.2.1.3, 28.2.2.2.2.3, 28.2.2.2.2.5.2, 28.2.2.2.2.5.3, and 28.2.2.2.3.1) requiring the evaluation of time versus engine variables.

28.2.2.1.1.2 Vibration Measurement Equipment - The vibration equipment used for measurement of engine case vibration shall have frequency response characteristics similar to the response characteristics of equipment used on previously Type Certificated engines.

28.2.2.1.2 Preliminary Data - The engine weight and center of gravity, if not previously obtained, photographs, and other pertinent engine data shall be obtained preferably at the time the engine is being prepared for test.

28.2.2.1.3 Operating Test Conditions

28.2.2.1.3.1 Inlet Distortion - All operation during the tests specified in 28.2.2.2.2.1 and 28.2.2.2.2.2 shall be with representative inlet distortion patterns, within facility limitations, as determined by airframe inlet tests but not to exceed the distortion limits specified in 10.0(a).

28.2.2.1.3.2 Oil Inlet Temperature - For all operation during the tests specified in 28.2.2.2.2.2, the main oil temperature at the location designated on the Installation Drawing shall be self-regulating.

Pratt & Whitney Aircraft
Specification No. 2710

28.2.2.1.3.3 Oil Servicing - The oil system shall be drained and filled with new oil at the start of the specific engine test. The use of external oil filters shall not be permitted. The oil system shall be further maintained in accordance with the requirements of P&WA.

28.2.2.1.3.4 Accreditable Test Time - Test time shall not be credited by increments shorter than 15 minutes, except when shorter periods are a test requirement.

28.2.2.1.3.5 Vapor Pressure Data - Wet and dry bulb air temperature readings shall be taken at intervals not exceeding 3 hours.

28.2.2.1.3.6 Barometer Readings - The barometer shall be read and recorded at intervals not exceeding 3 hours.

28.2.2.1.3.7 Miscellaneous Data - The date, operating schedule, engine model designation, and serial number shall be recorded on each log sheet.

28.2.2.1.3.8 Test Notes - Notes shall be placed on the log sheets of all incidents of the run, such as leaks, vibration, and other irregular functioning of the engine or the equipment, and corrective measures taken.

28.2.2.1.3.9 Correction - Readings of thrust, rpm, airflow rate, fuel flow rate, specific fuel consumption, gas pressures, and gas temperatures shall be corrected to standard sea level atmospheric conditions as defined in 1962 U.S. Standard Atmosphere (Geometric) conditions. In order to determine conformance with the engine performance ratings, the corrected thrust and specific fuel consumption shall be determined for all rated conditions by P&WA standard analytical and correction procedures.

28.2.2.1.3.9.1 Barometer Correction for Temperature - The barometer shall be corrected for temperature.

28.2.2.2 Endurance Test

28.2.2.2.1 Calibrations and Checks - Performance during calibrations and checks shall meet the requirements specified herein. Operating time during calibrations shall be limited to the minimum practicable.

28.2.2.2.1.1 Electrical and Electronic Interference and Susceptibility Check - An interference and susceptibility check in accordance with 18.2 shall be made on all electrical and electronic components or systems of the test engine prior to initiation of the flight test status test. Solenoid valves and position indicator switches shall not be contributing interference since the interference duration is approximately 1 second and will have an infrequent recurrence rate.

28.2.2.2.1.2 Engine Control System Calibration - Prior to the initiation of the engine calibration specified in 28.2.2.2.1.3, the components of the engine control system shall undergo bench calibration using test fluid in accordance with the specification fuel to determine conformance with the design tolerance range required by P&WA. The calibration shall include a measurement of power lever torque.

28.2.2.2.1.3 Engine Calibration - The procedure during the engine calibration shall be such as to establish the sea level static performance characteristics of the complete turbofan engine prior to the endurance run. Calibrations shall be made with a P&WA bellmouth, no accessory power extraction, without loading the accessory drives, and with no compressor bleed airflow other than that required for continuous engine operation, except where specified. The following data shall be obtained:

- a. Steady state data: Data required to establish compliance with applicable sea level performance characteristics covered by table I.
- b. Transient data: Data required to demonstrate engine starting and thrust transients.
- c. Repeat items "a" and "b" above with maximum permissible compressor bleed airflow, to determine the effect of air bleed on engine performance.

28.2.2.2.2 Procedure - Following the calibration run, the control shall be adjusted to produce at least the takeoff rated thrust with the power lever in the takeoff thrust position. During the test the engine shall be adjusted as necessary to maintain the rated thrust. The test shall be conducted in accordance with 28.2.2.2.2.1 and 28.2.2.2.2.2. P&WA may establish the order of runs in each cycle to accommodate best utilization of the test facility. The time for changing thrust shall be charged to the duration time at the lower setting. For all power lever movements, the power lever shall be advanced or retarded, as applicable, in not more than 1 second during the applicable test specified in 28.2.2.2.2.1 and 1 minute during the applicable test specified in 28.2.2.2.2.2.

28.2.2.2.2.1 Part 1 - The 25-hour sea level endurance test shall consist of 5 cycles of 5 hours each to be conducted in accordance with the schedule listed below and as shown on figure A-1. At least 2 of these cycles shall be at the maximum specified fuel inlet pressure. The 2nd cycle shall be accomplished with 3% gas generator bleed airflow. All other cycles shall be with no compressor air bleed flow other than that required for continuous engine operation.

- a. Takeoff thrust run - Thirty minutes consisting of five 6-minute periods, in each of which 5 minutes shall be run with the power lever in the Takeoff Augmented thrust position, and 1 minute with the power lever in the 95% Takeoff Nonaugmented thrust position.
- b. Cruise augmented thrust run - One hour with the sea level power setting corresponding to Cruise Partially Augmented thrust (reference table II).

Pratt & Whitney Aircraft
Specification No. 2710

- c. Takeoff Augmented thrust - Idle thrust run - Thirty minutes consisting of five 6-minute periods, in each of which 4 minutes shall be run with the power lever in the Takeoff Augmented thrust position, and 2 minutes with the power lever in the Idle thrust position.
- d. 95% Takeoff Nonaugmented thrust run - Forty-five minutes with the power setting corresponding to 95% Takeoff Nonaugmented thrust.
- e. 85% Takeoff Nonaugmented thrust run - Twenty-one minutes with the power lever in the position corresponding to 85% Takeoff Nonaugmented thrust.
- f. Reverse thrust run - Nine minutes in the sequence of power lever positions and time durations as follows: 1 minute Idle, 1 minute Maximum Reverse thrust, 6 minutes alternating 1 minute each at Takeoff Augmented thrust and Maximum Reverse thrust, and 1 minute Idle.
- g. Thrust transients run - Thirty minutes of thrust transients, consisting of 6 cycles in the sequence of power lever position from Idle thrust to Takeoff Augmented thrust, maintained at Takeoff Augmented for 60 ± 3 seconds, retarded to Idle, and maintained for approximately 4 minutes. One cycle will be accomplished with the augmentation lightoff at minimum augmented power lever position.
- h. Incremental thrust run - One hour and 15 minutes consisting of 5 minutes with the power lever position corresponding to each of the following percentages of Takeoff Nonaugmented thrust: 15, 25, 35, 40, 45, 50, 55, 60, 65, 70, 75, 80, 85, 95, 100. This portion of the test may be revised to include additional time at the vibratory speeds and elimination of some intermediate points.

28.2.2.2.2.2 Part 2 - The 50-hour heated inlet air test shall be conducted on the engine which completed Part 1 above, without the reverser-suppressor installed. The test shall consist of 12 cycles of 4 hours and 10 minutes each to be conducted in accordance with the schedule listed below and as shown on figure A-2 (curve A). The engine inlet air and the air that passes over the engine will be conditioned as shown on figures A-2 (curve B), and A-3 (curve A) within the tolerances of the facility. The fuel temperature at the fuel pump inlet will be as shown on figure A-3 (curve B) within the tolerance of the facility. This portion of the Flight Test Status endurance test shall be conducted, within facility limitations, as follows:

- a. Maximum Augmented thrust run - Seven minutes with the power lever position corresponding to the Maximum Augmented thrust position.
- b. Maximum cruise thrust run - Twenty-four minutes with the power lever position corresponding to 55% of Maximum Augmented thrust.
- c. Minimum Cruise thrust run - Twenty-four minutes with the power lever position corresponding to 40% of Maximum Augmented thrust.
- d. Idle descent run - Sixteen minutes with the power lever in the Idle thrust position.

Pratt & Whitney Aircraft
Specification No. 2710

- e. Airport departure maneuver, Cruise Part Power run - Fifteen minutes with the power lever position corresponding to 20% of Takeoff Nonaugmented thrust.
- f. Maximum augmented thrust run - Thirteen minutes with the power lever position corresponding to the Maximum Augmented thrust position.
- g. Maximum cruise thrust run - Fifty-five minutes with the power lever position corresponding to 55% of Maximum Augmented thrust.
- h. Minimum cruise thrust run - Fifty-five minutes with the power lever position corresponding to 40% of Maximum Augmented thrust.
- i. Subsonic cruise nonaugmented run - Twenty-five minutes with the power lever position corresponding to 50% of Takeoff Nonaugmented thrust.
- j. Idle descent run - Sixteen minutes with the power lever in the Idle thrust position.

Two augmentation system lightoffs shall be made during each cycle.

28.2.2.2.2.3 Starts - A minimum of 25 sea level static starts shall be made on the endurance test engine. There shall be at least 10 starts each preceded by at least a 2-hour shutdown. At least one of these 10 starts shall be made during or at the beginning of each 2 successive cycles. In addition, there shall be 5 false starts (a starting sequence without benefit of ignition, followed immediately after the permissible engine drainage procedure by a successful start), and 5 restarts (a start within a maximum of 15 minutes time from shutdown). If necessary, additional starts required to bring the total to 25 may be made at the end of the endurance test. The false starts may be conducted on an outdoor test stand using an engine not necessarily the endurance test engine.

28.2.2.2.2.4 Altitude Test - An engine, substantially identical to but not necessarily the same engine which completed 28.2.2.2.2.1 and 28.2.2.2.2.2, shall be subjected to altitude tests to substantiate the altitude performance specified in table 11 as modified by 6.1 in Appendix A.

28.2.2.2.2.5 Data

28.2.2.2.2.5.1 Steady-State Data - During the endurance test, except for the thrust transient runs, the following data shall be recorded, where applicable, at intervals not greater than 30 minutes or once during each test run, whichever is shorter:

- Time of day.
- Total endurance time.
- Power lever position.
- Exhaust nozzle position.
- Engine rotor speeds, rpm.
- Fuel consumption, lb/hr.
- *Data for determining airflow.
- Engine inlet total pressure, in. Hg. abs.

Pratt & Whitney Aircraft
Specification No. 2710

- Engine inlet total temperature, °F (°C).
- *Compressor air bleed total pressure, psia.
- Compressor air bleed static pressure, psia.
- Turbine discharge total pressure, psia.
- *Exhaust total pressure, psia.
- Exhaust static pressure, in. Hg. abs (if different from the barometer readings).
- Oil pressure at pressure pump outlet, psig.
- Fuel pressure at fuel system inlet, psig.
- Fuel pressure at point shown on Installation Drawing, psig.
- Fuel temperature at fuel system inlet, °F (°C).
- Measured steady-state turbine exhaust gas temperature, °F(°C).
- Duct heater fuel flow, lb/hr.
- Engine case vibration at points shown on Installation Drawing, mils.
- *Ignition source voltage and current (while starting).
- Engine Main Oil Temperature °F (°C).
- Breather Pressure, psia.

*Note: Items marked with an asterisk need be recorded during calibrations only. The oil consumption, oil specific gravity, fuel specific gravity, and fuel lower heating value shall be measured at suitable intervals.

28.2.2.2.2.5.2 Thrust Transient Data - For each thrust transient performed during the thrust transient and reverse thrust runs, the maximum values of measured gas temperature, thrust, fuel flow, and engine speed attained during the thrust transients shall be recorded.

28.2.2.2.2.5.3 Starting Data - During the starts conducted under 28.2.2.2.2.3, the following data shall be recorded for each start performed:

- Ambient temperature.
- Start number.
- *Time to ignition.
- *Time to starter cut out.
- Time to stabilize ground idle rpm.
- *Rpm at ignition.
- *Rpm at starter cut out.
- Maximum measured gas temperature.

Note: Items marked with an asterisk need be recorded only during calibration, recalibration, and 2 successive starts at the beginning and the end of the endurance test, at least one of which will be after a 2-hour shutdown. These data will also be recorded during one of the false starts.

In addition, records of starter torque versus revolutions per minute (rpm) shall be made during calibration, recalibration and 5 successive starts of the endurance test. Starter torque versus rpm testing may be waived if acceptable data are available from another equivalent engine.

28.2.2.2.3 Recalibrations

28.2.2.2.3.1 Engine Recalibration - After completion of the tests specified in 28.2.2.2.2.1 and 28.2.2.2.2.2, a recalibration check run in accordance with 28.2.2.2.1.3 "a" and "b" as modified shall be made on the endurance test engine. During the recalibration check run, the engine shall be adjusted to produce on a standard day, the nonaugmented thrust or maximum turbine discharge temperature, whichever is lower, that was obtained during the initial calibration. During maximum augmented operation, duct heater fuel flow shall be adjusted so that, on a standard day, the total fuel flow will correspond to the level that was obtained during the initial calibration. During this run the corrected jet thrust shall be not less than 95% of the initial calibration values, and the corrected specific fuel consumptions shall not exceed 105% of the initial calibration values. The engine shall meet all other specified performance requirements which can be checked by the calibration procedure. The check run may be preceded by a run-in period during which the cleaning procedure recommended for field use by P&WA may be applied.

28.2.2.2.3.2 Engine Control System Recalibration - After completion of the engine recalibration specified in 28.2.2.2.3.1, the components of the engine control system shall undergo a bench recalibration to determine conformance with the design tolerance range required by P&WA. For this recalibration, external engine control adjustments shall be established at their pre-test bench calibration positions.

28.2.3 Engine Components Test - P&WA will supply suitable data on engine component tests. Components used for these tests shall be substantially identical with those used on the endurance tests. The instrumentation to be delivered with the FTS engine shall not be subject to FTS test approval.

28.2.4 Teardown Inspection - After completion of the tests, the engine and components shall be completely disassembled for examination of all parts and measured, as necessary, to disclose excessively worn, distorted, or weakened parts. These measurements shall be compared with the drawing dimensions and tolerances, or with similar measurements made prior to the test when available.

28.2.5 General Inspection - All tests shall be subject to witnessing by a Government representative. The engine and components shall be examined to determine if they conform to all requirements of the contract and specification under which they were built. At convenient times prior to the tests and during teardown inspections the engine and components shall be examined to determine if they conform to all requirements of the contract and specifications under which they were built. Inspection of the engine during the test may be conducted between the test cycles at the discretion of P&WA. External adjustments normally performed during routine maintenance may be made at the discretion of P&WA. Part changes may be made during the test provided that such part subsequently completes that portion of the test run prior to its installation. This requirement may be accomplished on the same engine or another engine assembled essentially to the same parts list. The Government representative shall be notified of any such maintenance, adjustment or parts change."

Figure A-1

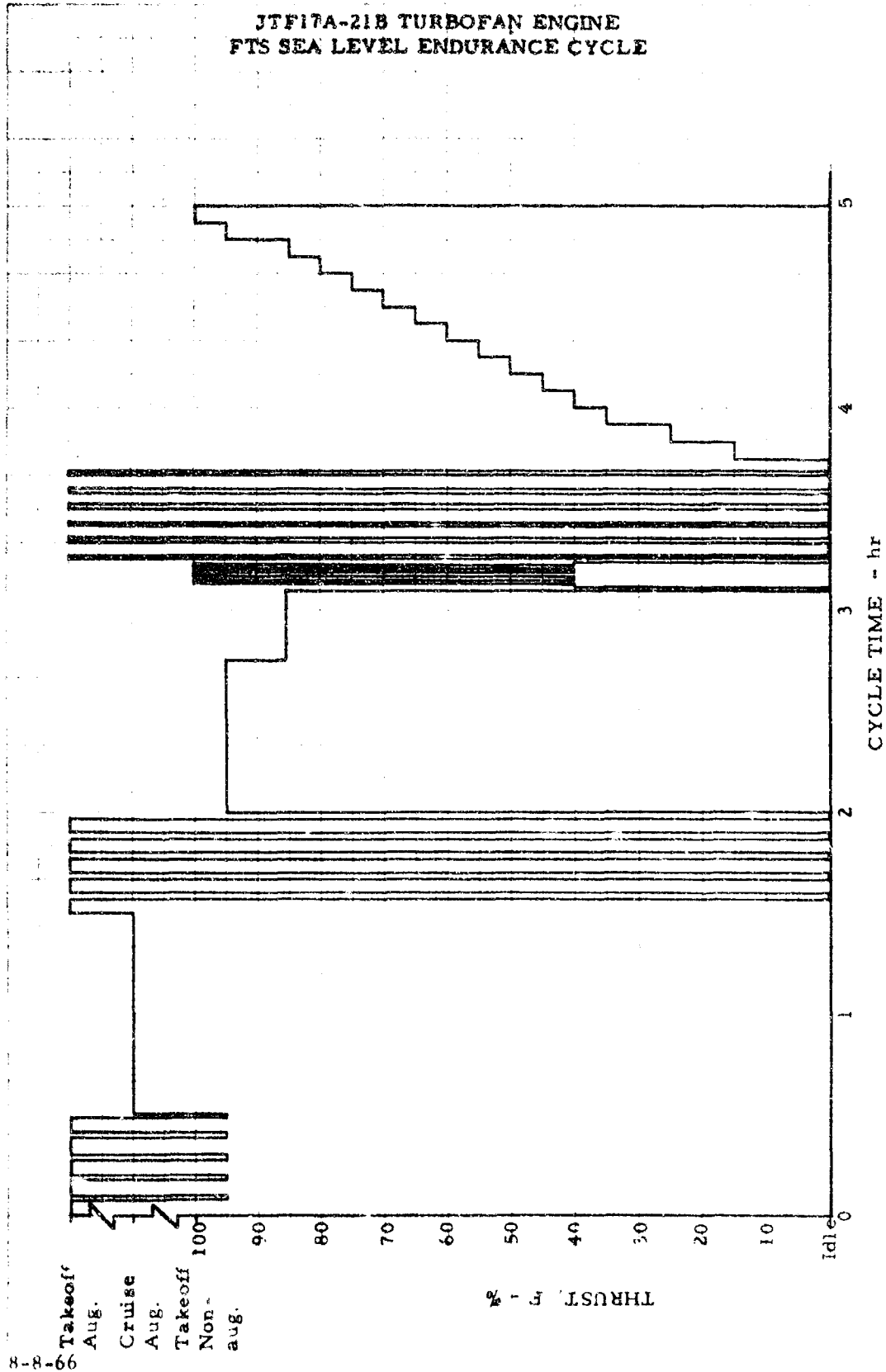
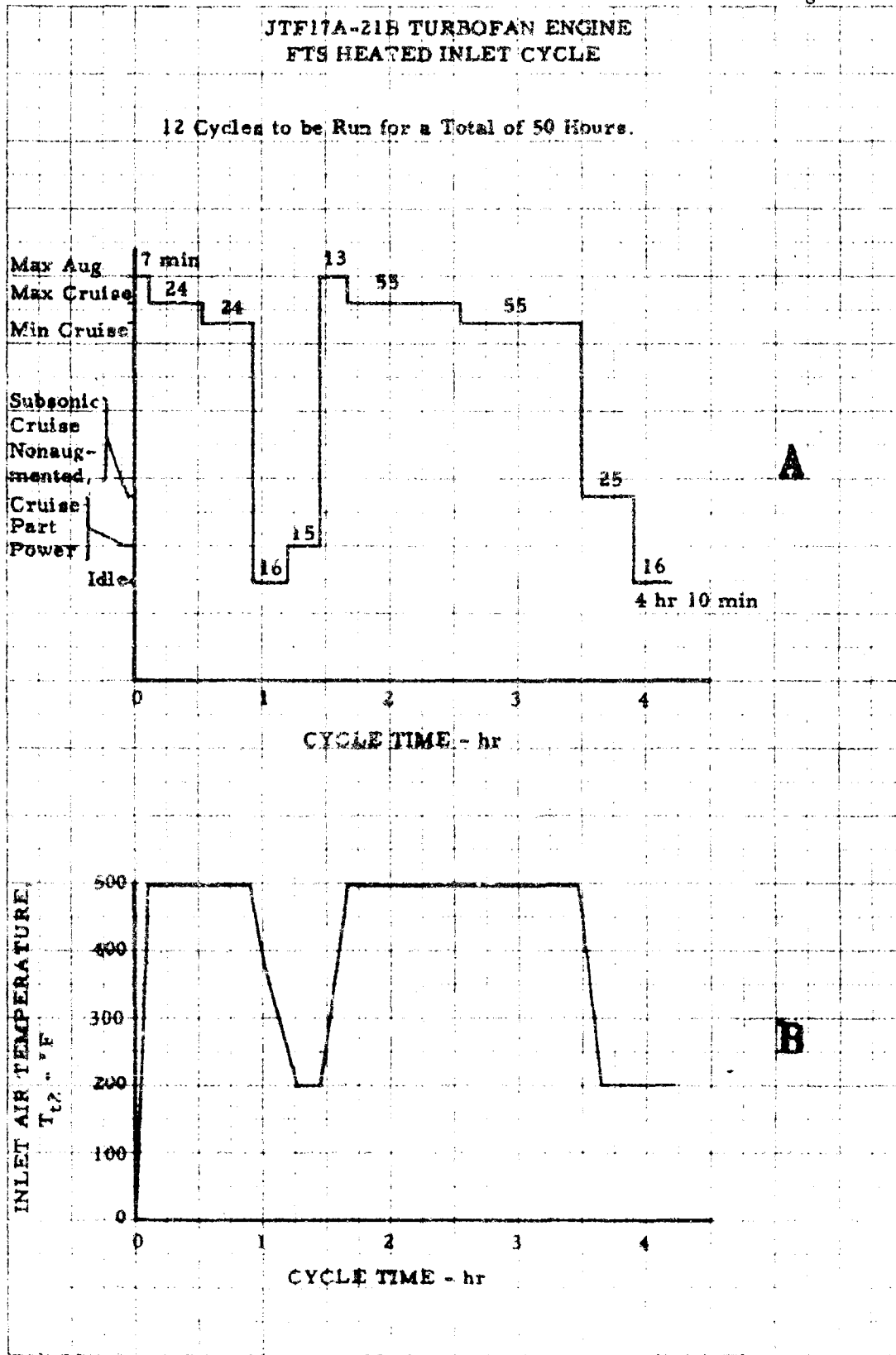
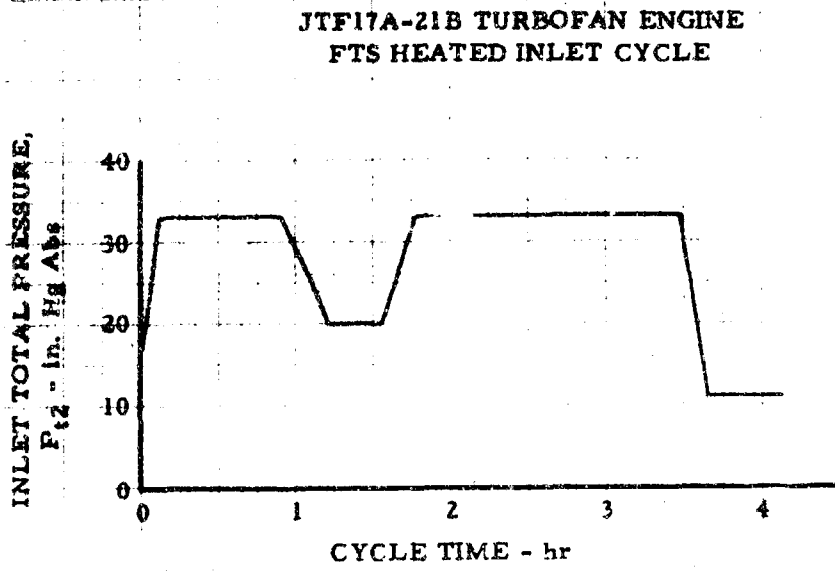

Figure A-2



8-8-66

Figure A-3



A

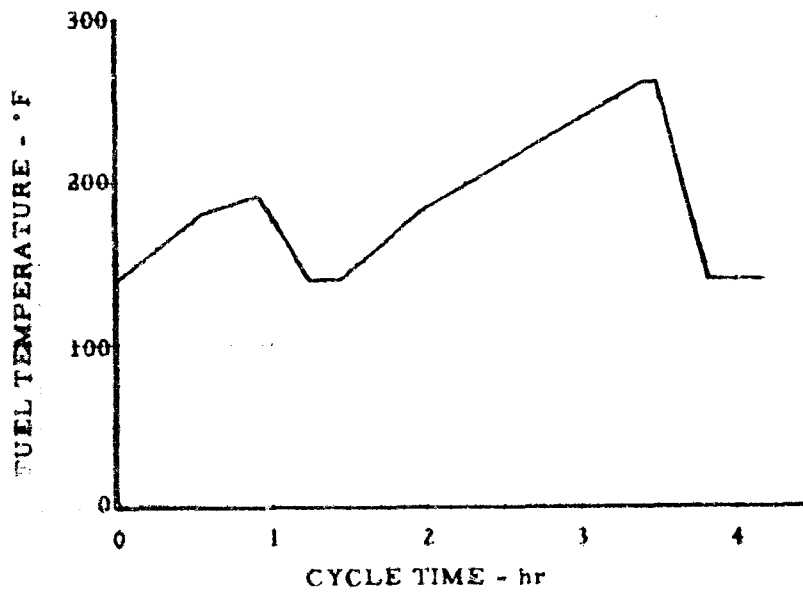

B

8-8-66

ENGINE INSTALLATION DRAWING
FOR JTF17A-21B PROTOTYPE
IDENTICAL TO 2129601-SHEETS
1, 2, 3, 4 - ENGINE INSTALLATION
JTF17A-21B PRODUCTION

AUGUST 8, 1966
PRELIMINARY
SUBJECT
TO
CHANGE

PRATT & WHITNEY AIRCRAFT
CONTROLLED *u/s/1-6*

NOTICE TO ALL PERSONS RECEIVING THIS DRAWING

DESIGN	DV	Pratt & Whitney Aircraft	U
	8566	DIVISION OF UNITED AIRCRAFT CORPORATION	A
CHECKED		EAST HAMPTON, CONNECTICUT	
	<i>C.M. Sims</i>	ENGINE INSTALLATION (F.T.S.) (JTF17A-21B PROTOTYPE)	
APPROVED	<i>A.S.H.</i>		
DRAWING REFERENCE DATA		PREPARED UNDER CONTRACT	CODE IDENT NO.
FIRST RELEASE - ENGINE TYPE	JTF17	FA-SS-66-8	77445
LAYOUTS		PUBLISHED UNDER CONTRACT	SIZE
REF PART NO			A
		SCALE	2130301
		APPROX WT	LB
			SHEET

NO. 1120 PUBLISHED 10/1/64

ALLOWABLE LOADS DRAWING
FOR JTF17A-21B PROTOTYPE
IDENTICAL TO 2128091
ALLOWABLE LOAD INSTALLATION
JTF17A-21B PRODUCTION

AUGUST 8, 1966
PRELIMINARY
SUBJECT
TO
CHANGE

PRATT & WHITNEY AIRCRAFT
CONTROLLED *u/s/1-6*

NOTICE TO ALL PERSONS RECEIVING THIS DRAWING

DESIGN	GWG	Pratt & Whitney Aircraft	U
	8566	DIVISION OF UNITED AIRCRAFT CORPORATION	A
CHECKED		EAST HAMPTON, CONNECTICUT	
	<i>C.M. Sims</i>	LOAD INSTALLATION (F.T.S.) ALLOWABLE FLIGHT, SHIPPING & GROUND HANDLING (JTF17A-21B PROTOTYPE)	
APPROVED	<i>A.S.H.</i>		
DRAWING REFERENCE DATA		PREPARED UNDER CONTRACT	CODE IDENT NO.
FIRST RELEASE - ENGINE TYPE	JTF17	FA-SS-66-8	77445
LAYOUTS		PUBLISHED UNDER CONTRACT	SIZE
REF PART NO			A
		SCALE	2130140
		APPROX WT	LB
			SHEET

NO. 1120 PUBLISHED 10/1/64

<p>PRINTED IN THE UNITED STATES OF AMERICA</p> <p>ELECTRICAL INSTALLATION DIAGRAM FOR JTF17A-21B PROTOTYPE IDENTICAL TO 2129603 ELECTRICAL INSTALLATION JTF17A-21B PRODUCTION</p>		<p>AUGUST 8, 1966 PRELIMINARY SUBJECT TO CHANGE</p>											
<p>PRATT & WHITNEY AIRCRAFT CONTROLLED <i>u/s 8/10/66</i></p>													
<p>NOTICE TO ALL PERSONS RECEIVING THIS DRAWING This drawing is the property of Pratt & Whitney Aircraft, Inc. and is loaned to you for your information only. It is not to be distributed outside your organization. It is to be returned to Pratt & Whitney Aircraft, Inc. when you are no longer in possession of it. It is not to be used for any other purpose than that for which it was loaned to you. It is not to be reproduced in any form without the written consent of Pratt & Whitney Aircraft, Inc.</p>													
<table border="1" style="width: 100%; border-collapse: collapse;"> <tr> <td style="width: 50%; font-size: x-small;">DRAWN</td> <td style="width: 50%; font-size: x-small;">DY</td> </tr> <tr> <td style="font-size: x-small;">CHECKED</td> <td style="font-size: x-small;">R.A.S.</td> </tr> <tr> <td style="font-size: x-small;">APPROVED</td> <td style="font-size: x-small;">R.E.M.</td> </tr> </table>	DRAWN	DY	CHECKED	R.A.S.	APPROVED	R.E.M.	<table border="1" style="width: 100%; border-collapse: collapse;"> <tr> <td style="width: 50%; font-size: x-small;">Pratt & Whitney Aircraft</td> <td style="width: 50%; text-align: center; font-size: x-small;">U DIVISION OF UNITED AIRCRAFT CORPORATION A SEC. HISTORY, SECURITY</td> </tr> <tr> <td colspan="2" style="text-align: center;"> <p>DIAGRAM-ELECTRICAL INSTALLATION CONNECTION (JTF17A-21B PROTOTYPE)</p> </td> </tr> </table>			Pratt & Whitney Aircraft	U DIVISION OF UNITED AIRCRAFT CORPORATION A SEC. HISTORY, SECURITY	<p>DIAGRAM-ELECTRICAL INSTALLATION CONNECTION (JTF17A-21B PROTOTYPE)</p>	
DRAWN	DY												
CHECKED	R.A.S.												
APPROVED	R.E.M.												
Pratt & Whitney Aircraft	U DIVISION OF UNITED AIRCRAFT CORPORATION A SEC. HISTORY, SECURITY												
<p>DIAGRAM-ELECTRICAL INSTALLATION CONNECTION (JTF17A-21B PROTOTYPE)</p>													
DRAWING REFERENCE DATA	PREPARED UNDER CONTRACT	CODE IDENT. NO.	DATE										
FIRST RELEASE - ENGINE TYPE <u>JTF17</u>	FA-55-66-8	77445	A										
LAWRENCE	PURNISHED UNDER CONTRACT	2130303	SCALE										
REV PART NO.	SCALE	APPROX WT	LB SHEET										

Best Available Copy

Best Available Copy